

## FEATURES

- **Controlled Baseline**
  - One Assembly/Test Site, One Fabrication Site
- **Extended Temperature Performance of –55°C to 125°C**
- **Enhanced Diminishing Manufacturing Sources (DMS) Support**
- **Enhanced Product-Change Notification**
- **Qualification Pedigree <sup>(1)</sup>**
- **100-mΩ, 4.5-A Peak MOSFET Switch for High Efficiency at 3-A Continuous Output Current**
- **Use External Low-Side MOSFET or Diode**
- **Fixed-Output Versions – 1.2 V/1.5 V/1.8 V/ 2.5 V/3.3 V/5 V**
- **Internally Compensated for Low Parts Count**
- **Synchronize to External Clock**
- **180° Out-of-Phase Synchronization**
- **Wide Pulse Width Modulation (PWM) Frequency – Fixed 250 kHz, 500 kHz, or Adjustable 250 kHz to 700 kHz**
- **Internal Slow Start**
- **Load Protected by Peak Current Limit and Thermal Shutdown**
- **Adjustable Undervoltage Lockout**
- **16-Pin PowerPAD™ Thin Shrink Small-Outline Package (TSSOP) (PWP)**

(1) Component qualification in accordance with JEDEC and industry standards to ensure reliable operation over an extended temperature range. This includes, but is not limited to, Highly Accelerated Stress Test (HAST) or biased 85/85, temperature cycle, autoclave or unbiased HAST, electromigration, bond intermetallic life, and mold compound life. Such qualification testing should not be viewed as justifying use of this component beyond specified performance and environmental limits.

## DESCRIPTION/ORDERING INFORMATION

The TPS5435x is a medium-output-current synchronous buck PWM converter with an integrated high-side MOSFET and a gate driver for an optional low-side external MOSFET. Features include a high-performance voltage error amplifier that enables maximum performance under transient conditions. The TPS5435x has an undervoltage lockout (UVLO) circuit to prevent start-up until the input voltage reaches a preset value, an internal slow-start circuit to limit in-rush currents, and a power-good (PWRGD) output to indicate valid output conditions. The synchronization feature is configurable as either an input or an output for easy 180° out-of-phase synchronization.

The TPS5435x devices are available in a thermally enhanced 16-pin PowerPAD™ Thin Shrink Small-Outline Package (TSSOP). TI provides evaluation modules and the SWIFT™ Designer software tool to aid in quickly achieving high-performance power-supply designs to meet aggressive equipment development cycles.



Please be aware that an important notice concerning availability, standard warranty, and use in critical applications of Texas Instruments semiconductor products and disclaimers thereto appears at the end of this data sheet.

SWIFT, PowerPAD are trademarks of Texas Instruments.

## APPLICATIONS

- **Industrial and Commercial Low-Power Systems**
- **LCD Monitors and TVs**
- **Computer Peripherals**
- **Point-of-Load Regulation for High Performance DSPs, FPGAs, ASICs, and Microprocessors**

### SIMPLIFIED SCHEMATIC

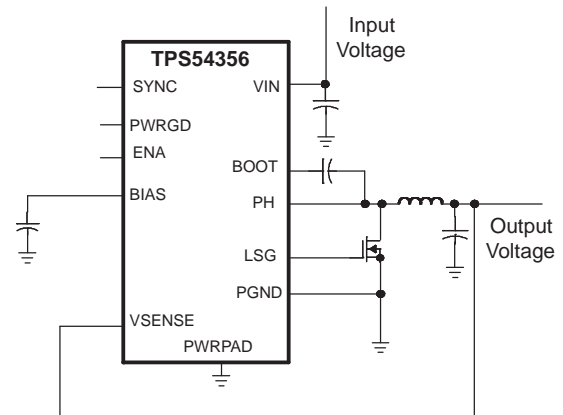

### EFFICIENCY vs OUTPUT CURRENT

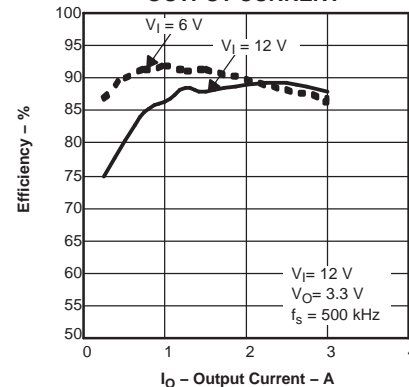

**TPS54352-EP, TPS54353-EP, TPS54354-EP, TPS54355-EP, TPS54356-EP, TPS54357-EP**  
**4.5-V TO 20-V INPUT, 3-A OUTPUT SYNCHRONOUS PWM SWITCHES**  
**WITH INTEGRATED FET (SWIFT™)**

SLVS684–JANUARY 2007



These devices have limited built-in ESD protection. The leads should be shorted together or the device placed in conductive foam during storage or handling to prevent electrostatic damage to the MOS gates.

**ORDERING INFORMATION**

T <sub>J</sub>	PACKAGE <sup>(1)</sup>	OUTPUT VOLTAGE	PART NUMBER	PACKAGE MARKING
–55°C to 125°C	Plastic HTSSOP – PWP	1.2 V	TPS54352MPWPREP <sup>(2)</sup>	TBD
	Plastic HTSSOP – PWP	1.5 V	TPS54353MPWPREP <sup>(2)</sup>	TBD
	Plastic HTSSOP – PWP	1.8 V	TPS54354MPWPREP	PMDM
	Plastic HTSSOP – PWP	2.5 V	TPS54355MPWPREP <sup>(2)</sup>	TBD
	Plastic HTSSOP – PWP	3.3 V	TPS54356MPWPREP	PMEM
	Plastic HTSSOP – PWP	5 V	TPS54357MPWPREP <sup>(2)</sup>	TBD

(1) The PWP package also is available taped and reeled. Add an R suffix to the device type (i.e., TPS5435xPWPR).

(2) Product preview

**Absolute Maximum Ratings<sup>(1)</sup>**

over operating free-air temperature range (unless otherwise noted)

		UNIT
Input voltage range, V <sub>I</sub>	VIN	–0.3 V to 21.5 V
	VSENSE	–0.3 V to 8 V
	UVLO	–0.3 V to 8 V
	SYNC	–0.3 V to 4 V
	ENA	–0.3 V to 4 V
	BOOT	VI(PH) + 8 V
Output voltage range, V <sub>O</sub>	VBIAS	–0.3 V to 8.5 V
	LSG	–0.3 V to 8.5 V
	SYNC	–0.3 V to 4 V
	RT	–0.3 V to 4 V
	PWRGD	–0.3 V to 6 V
	COMP	–0.3 V to 4 V
	PH	–1.5 V to 22 V
Source current, I <sub>O</sub>	PH	Internally Limited (A)
	LSG (steady-state current)	10 mA
	COMP, VBIAS	3 mA
Sink current, I <sub>S</sub>	SYNC	5 mA
	LSG (steady-state current)	100 mA
	PH (steady-state current)	500 mA
	COMP	3 mA
	ENA, PWRGD	10 mA
Voltage differential	AGND to PGND	±0.3 V
Operating virtual junction temperature range, T <sub>J</sub>		–55°C to 150°C
Storage temperature range, T <sub>stg</sub>		–65°C to 150°C
Lead temperature 1,6 mm (1/16 in) from case for 10 s		260°C

(1) Stresses beyond those listed under "absolute maximum ratings" may cause permanent damage to the device. These are stress ratings only, and functional operation of the device at these or any other conditions beyond those indicated under "recommended operating conditions" is not implied. Exposure to absolute-maximum-rated conditions for extended periods may affect device reliability.

## Electrostatic Discharge (ESD) Protection

	MIN	MAX	UNIT
Human-Body Model (HBM)		600	V
Charged-Device Model (CDM)		1.5	kV

## Recommended Operating Conditions

		MIN	MAX	UNIT
Input voltage range, $V_I$	TPS54352-6	4.5	20	V
	TPS54357	6.65	20	
Operating junction temperature, $T_J$		-55	125	°C

## Electrical Characteristics

 $T_J = -55^\circ\text{C}$  to  $125^\circ\text{C}$ ,  $V_{IN} = 4.5\text{ V}$  to  $20\text{ V}$  (unless otherwise noted)

PARAMETER		TEST CONDITIONS	MIN	TYP	MAX	UNIT	
<b>Supply Current</b>							
$I_Q$	Quiescent current	Operating current, PH pin open, No external low side MOSFET, RT = Hi-Z		5		mA	
		Shutdown, ENA = 0 V		1			
$V_{IN}$	Start threshold voltage	TPS54352-6		4.32	4.48	V	
		TPS54357		6.4	6.65		
	Stop threshold voltage	TPS54352-6		3.69	3.97	V	
		TPS54357		5.45	5.8		
Hysteresis	TPS54352-6			350		mV	
	TPS54357			600			
<b>Output Voltage</b>							
$V_O$	Output voltage	TPS54352	$T_J = 25^\circ\text{C}$ , $I_O = 100\text{ mA}$ to $3\text{ A}$	1.88	1.2	1.212	V
			$I_O = 100\text{ mA}$ to $3\text{ A}$	1.176	1.2	1.224	
		TPS54353	$T_J = 25^\circ\text{C}$ , $I_O = 100\text{ mA}$ to $3\text{ A}$	1.485	1.5	1.515	
			$I_O = 100\text{ mA}$ to $3\text{ A}$	1.47	1.5	1.53	
		TPS54354	$T_J = 25^\circ\text{C}$ , $I_O = 100\text{ mA}$ to $3\text{ A}$	1.782	1.8	1.818	
			$I_O = 100\text{ mA}$ to $3\text{ A}$	1.764	1.8	1.836	
		TPS54355	$T_J = 25^\circ\text{C}$ , $I_O = 100\text{ mA}$ to $3\text{ A}$	2.475	2.5	2.525	
			$I_O = 100\text{ mA}$ to $3\text{ A}$	2.45	2.5	2.55	
		TPS54356	$T_J = 25^\circ\text{C}$ , $V_{IN} = 5.5\text{ V}$ to $20\text{ V}$ , $I_O = 100\text{ mA}$ to $3\text{ A}$	3.267	3.3	3.333	
			$V_{IN} = 5.5\text{ V}$ to $20\text{ V}$ , $I_O = 100\text{ mA}$ to $3\text{ A}$	3.234	3.3	3.366	
		TPS54357	$T_J = 25^\circ\text{C}$ , $V_{IN} = 7.5\text{ V}$ to $20\text{ V}$ , $I_O = 100\text{ mA}$ to $3\text{ A}$	4.95	5	5.05	
			$V_{IN} = 7.5\text{ V}$ to $20\text{ V}$ , $I_O = 100\text{ mA}$ to $3\text{ A}$	4.9	5	5.1	
<b>Under Voltage Lockout (UVLO)</b>							
UVLO	Start threshold voltage			1.2	1.25	V	
	Stop threshold voltage		1.02	1.1		V	
	Hysteresis			100		mV	
<b>Bias Voltage (VBIAS)</b>							
VBIAS	Output voltage	$I_{VBIAS} = 5\text{ mA}$ , $V_{IN} \geq 12\text{ V}$	7.5	7.8	8	V	
		$I_{VBIAS} = 5\text{ mA}$ , $V_{IN} = 4.5\text{ V}$	4.4	4.47	4.5		
<b>Oscillator (RT)</b>							
	Internally set PWM switching frequency	RT grounded	200	250	300	kHz	
		RT open	400	500	600		
	Externally set PWM switching frequency	RT = 100 k $\Omega$ (1% resistor to AGND)	425	500	575	kHz	

## Electrical Characteristics (continued)

T<sub>J</sub> = –55°C to 125°C, V<sub>IN</sub> = 4.5 V to 20 V (unless otherwise noted)

PARAMETER		TEST CONDITIONS	MIN	TYP	MAX	UNIT
<b>Falling-Edge-Triggered Bidirectional Sync System (SYNC)</b>						
SYNC out low-to-high rise time (10%/90%) <sup>(1)</sup>		25 pF to ground		200	500	ns
SYNC out high-to-low fall time (90%/10%) <sup>(1)</sup>		25 pF to ground		5	10	ns
Falling-edge delay time <sup>(1)</sup>		Delay from rising edge to rising edge of PH pins, See <a href="#">Figure 19</a>		180		°
Minimum input pulse width <sup>(1)</sup>		RT = 100 kΩ		100		ns
Delay (falling-edge SYNC to rising-edge PH) <sup>(1)</sup>		RT = 100 kΩ		360		ns
SYNC out high-level voltage		50-kΩ resistor to ground, No pullup resistor	2.5			V
SYNC out low-level voltage					0.6	V
SYNC in low-level threshold			0.8			V
SYNC in high-level threshold					2.3	V
SYNC in frequency range <sup>(1)</sup>		Percentage of programmed frequency	–10%		10%	
			225		770	kHz
<b>Feed-Forward Modulator (Internal Signal)</b>						
Modulator gain		V <sub>IN</sub> = 12 V, T <sub>J</sub> = 25°C		8		
Modulator gain variation				±25%		
Minimum controllable ON time <sup>(1)</sup>				180		ns
Maximum duty factor <sup>(1)</sup>		V <sub>IN</sub> = 4.5 V	80%	86%		
<b>VSENSE</b>						
Input bias current, VSENSE				1		μA
<b>Enable (ENA)</b>						
Disable low-level input voltage					0.5	V
Internal slow-start time (10% to 90%)	TPS54352	f <sub>s</sub> = 250 kHz, RT = ground <sup>(1)</sup>		3.2		ms
		f <sub>s</sub> = 500 kHz, RT = Hi-Z <sup>(1)</sup>		1.6		
	TPS54353	f <sub>s</sub> = 250 kHz, RT = ground <sup>(1)</sup>		4		
		f <sub>s</sub> = 500 kHz, RT = Hi-Z <sup>(1)</sup>		2		
	TPS54354	f <sub>s</sub> = 250 kHz, RT = ground <sup>(1)</sup>		4.6		
		f <sub>s</sub> = 500 kHz, RT = Hi-Z <sup>(1)</sup>		2.3		
	TPS54355	f <sub>s</sub> = 250 kHz, RT = ground <sup>(1)</sup>		4.4		
		f <sub>s</sub> = 500 kHz, RT = Hi-Z <sup>(1)</sup>		2.2		
	TPS54356	f <sub>s</sub> = 250 kHz, RT = ground <sup>(1)</sup>		5.9		
		f <sub>s</sub> = 500 kHz, RT = Hi-Z <sup>(1)</sup>		2.9		
	TPS54357	f <sub>s</sub> = 250 kHz, RT = ground <sup>(1)</sup>		5.4		
		f <sub>s</sub> = 500 kHz, RT = Hi-Z <sup>(1)</sup>		2.7		
Pullup current source			1.8	5	10	μA
Pulldown MOSFET		I <sub>I(ENA)</sub> = 1 mA		0.1		V
<b>Power Good (PWRGD)</b>						
Power-good threshold		Rising voltage		97%		
Rising-edge delay <sup>(1)</sup>		f <sub>s</sub> = 250 kHz		4		ms
		f <sub>s</sub> = 500 kHz		2		
PWRGD	Output saturation voltage		I <sub>sink</sub> = 1 mA, V <sub>IN</sub> > 4.5 V		0.05	V
	Output saturation voltage		I <sub>sink</sub> = 100 μA, V <sub>IN</sub> = 0 V		0.76	V
	Open-drain leakage current		Voltage on PWRGD = 6 V			3

(1) Specified by design, not production tested

**Electrical Characteristics (continued)**
 $T_J = -55^{\circ}\text{C}$  to  $125^{\circ}\text{C}$ ,  $V_{IN} = 4.5\text{ V}$  to  $20\text{ V}$  (unless otherwise noted)

PARAMETER	TEST CONDITIONS	MIN	TYP	MAX	UNIT
<b>Current Limit</b>					
Current limit	$V_{IN} = 12\text{ V}$	3.3	4.5	6.5	A
Current-limit hiccup time <sup>(2)</sup>	$f_s = 500\text{ kHz}$		4.5		ms
<b>Thermal Shutdown</b>					
Thermal-shutdown trip point <sup>(2)</sup>			165		$^{\circ}\text{C}$
Thermal-shutdown hysteresis <sup>(2)</sup>			7		$^{\circ}\text{C}$
<b>Low-Side MOSFET Driver (LSG)</b>					
Turn-on rise time, (10/90%) <sup>(2)</sup>	$V_{IN} = 4.5\text{ V}$ , Capacitive load = $1000\text{ pF}$		15		ns
Deadtime	$V_{IN} = 12\text{ V}$		60		ns
Driver ON resistance	$V_{IN} = 4.5\text{ V}$ sink/source		7.5		$\Omega$
	$V_{IN} = 12\text{ V}$ sink/source		5		
<b>Output Power MOSFETS (PH)</b>					
Phase-node voltage when disabled	DC conditions and no load, $EN_A = 0\text{ V}$		0.5		V
Voltage drop, low-side FET and diode	$V_{IN} = 4.5\text{ V}$ , $I_{dc} = 100\text{ mA}$		1.13	1.42	V
	$V_{IN} = 12\text{ V}$ , $I_{dc} = 100\text{ mA}$		1.08	1.38	
$r_{DS(ON)}$ High-side power MOSFET switch <sup>(3)</sup>	$V_{IN} = 4.5\text{ V}$ , $BOOT-PH = 4.5\text{ V}$ , $I_O = 0.5\text{ A}$		150	300	$\text{m}\Omega$
	$V_{IN} = 12\text{ V}$ , $BOOT-PH = 8\text{ V}$ , $I_O = 0.5\text{ A}$		100	200	

(2) Specified by design, not production tested

 (3) Resistance from  $V_{IN}$  to PH pins

## PIN ASSIGNMENTS

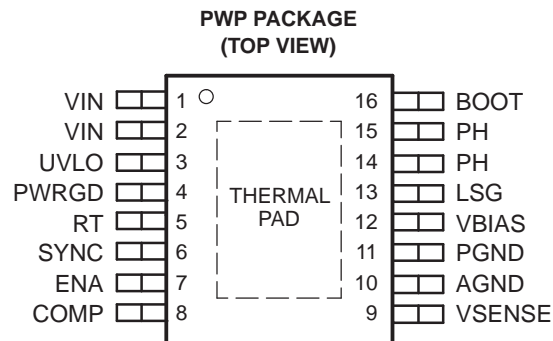

NOTE: If there is not a pin 1 indicator, turn device to enable reading the symbol from left to right. Pin 1 is at the lower left corner of the device.

## TERMINAL FUNCTIONS

TERMINAL		DESCRIPTION
NO.	NAME	
1, 2	VIN	Input supply voltage, 4.5 V to 20 V. Must bypass with a low ESR 10- $\mu$ F ceramic capacitor. Place cap as close to device as possible; see <a href="#">Figure 23</a> for an example.
3	UVLO	Undervoltage lockout. Connecting an external resistive voltage divider from VIN to the pin overrides the internal default VIN start and stop thresholds.
4	PWRGD	Power good output. Open-drain output. A low on the pin indicates that the output is less than the desired output voltage. There is an internal rising-edge filter on the output of the PWRGD comparator.
5	RT	Frequency setting. Connect a resistor from RT to AGND to set the switching frequency. Connecting the RT pin to ground or floating will set the frequency to an internally preselected frequency.
6	SYNC	Bidirectional synchronization I/O. SYNC is an output when the RT pin is floating or connected low. The output is a falling-edge signal out of phase with the rising edge of PH. SYNC may be used as an input to synchronize to a system clock by connecting to a falling edge signal when an RT resistor is used. See 180° Out of Phase Synchronization operation in the Application Information section. In all cases, a 10-k $\Omega$ resistor must be tied to the SYNC pin in parallel with ground. For information on how to extend slow start, see the Enable (ENA) and Internal Slow Start section.
7	ENA	Enable. Below 0.5 V, the device stops switching. Float pin to enable.
8	COMP	Error amplifier output. Do not connect anything to this pin.
9	VSENSE	Feedback
10	AGND	Analog ground. Internally connected to the sensitive analog ground circuitry. Connect to PGND and PowerPAD package.
11	PGND	Power ground. Noisy internal ground. Return currents from the LSG driver output return through the PGND pin. Connect to AGND and PowerPAD package.
12	VBIAS	Internal 8-V bias voltage. A 1- $\mu$ F ceramic bypass capacitance is required on the VBIAS pin.
13	LSG	Gate drive for optional low-side MOSFET. Connect gate of n-channel MOSFET for a higher efficiency synchronous buck converter configuration. Otherwise, leave open and connect Schottky diode from ground to PH pins.
14, 15	PH	Phase node. Connect to external L-C filter.
16	BOOT	Bootstrap capacitor for high-side gate driver. Connect a 0.1- $\mu$ F ceramic capacitor from BOOT to PH pins.
	PowerPAD	PGND and AGND pins must be connected to the exposed pad for proper operation. See <a href="#">Figure 23</a> for an example PCB layout.

## FUNCTIONAL BLOCK DIAGRAM

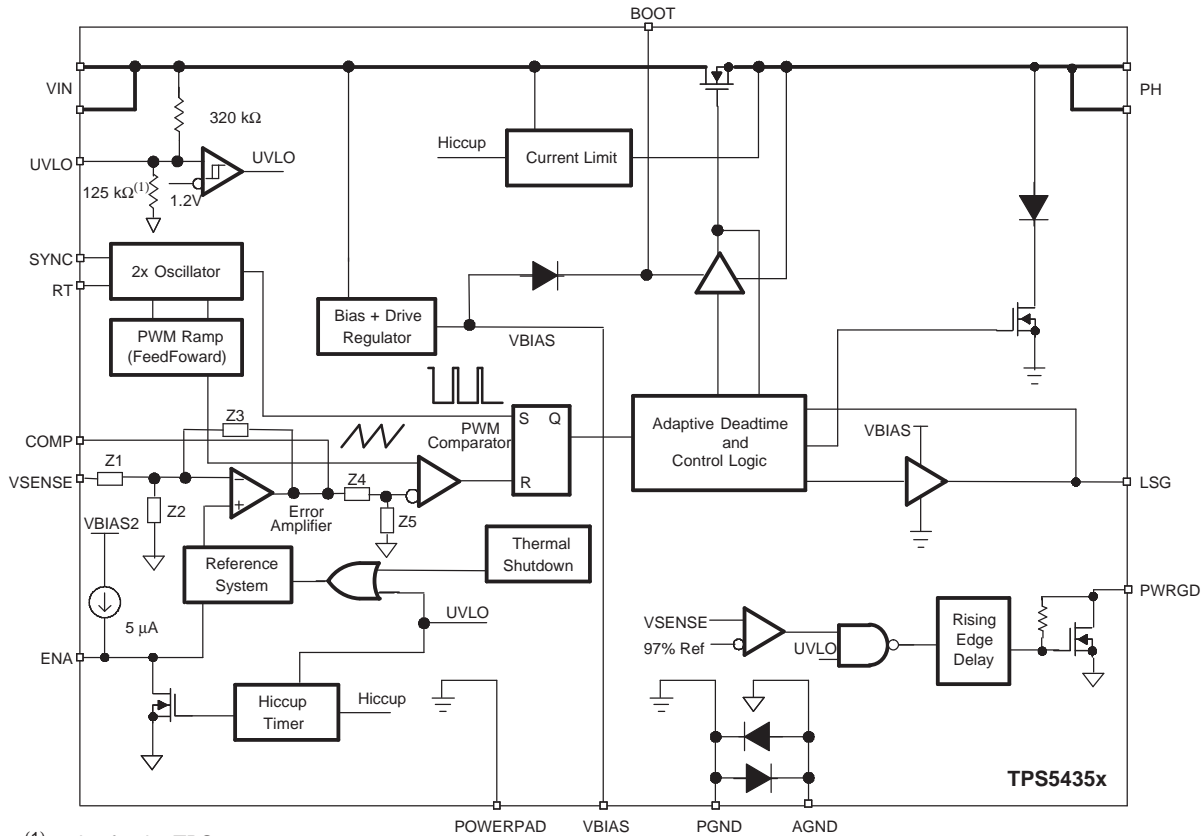

(1) 75 kΩ for the TPS54357

## DETAILED DESCRIPTION

### Undervoltage Lockout (UVLO)

The UVLO system has an internal voltage divider from VIN to AGND. The defaults for the start/stop values are labeled VIN and are given in Table 1. The internal UVLO threshold can be overridden by placing an external resistor divider from VIN to ground. The internal divider values are approximately 320 kΩ for the high-side resistor and 125 kΩ for the low-side resistor. The divider ratio (and, therefore, the default start/stop values) is quite accurate, but the absolute values of the internal resistors may vary as much as 15%. If high accuracy is required for an externally adjusted UVLO threshold, select lower-value external resistors to set the UVLO threshold. Using a 1-kΩ resistor for the low-side resistor (R2 see Figure 1) is recommended. Under no circumstances should the UVLO pin be connected directly to VIN.

Table 1. Start/Stop Voltage Threshold

		START VOLTAGE THRESHOLD	STOP VOLTAGE THRESHOLD
VIN (default)	TPS54352-6	4.49	3.69
	TPS54357	6.65	5.45
UVLO		1.24	1.02

The equations for selecting the UVLO resistors are:

$$R1 = \frac{VIN(\text{start}) \times 1 \text{ k}\Omega}{1.24 \text{ V}} - 1 \text{ k}\Omega \quad (1)$$

$$VIN(\text{stop}) = \frac{(R1 + 1 \text{ k}\Omega) \times 1.02 \text{ V}}{1 \text{ k}\Omega} \quad (2)$$

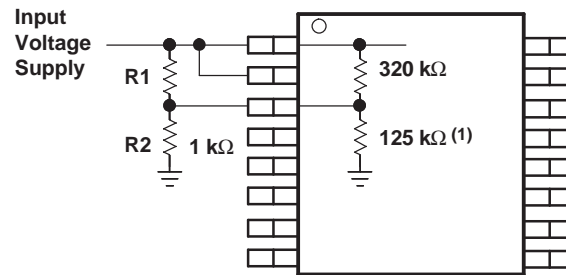

(1) 75 kΩ for the TPS54357

**Figure 1. Circuit Using External UVLO Function**

For applications that require an UVLO threshold greater than 4.49 V (6.6 V for TPS54357), external resistors may be implemented (see [Figure 1](#)) to adjust the start-voltage threshold. For example, an application needing a UVLO start voltage of approximately 7.8 V using equation 1, R1 is calculated to the nearest standard resistor value of 5.36 kΩ. Using equation 2, the input voltage stop threshold is calculated as 6.48 V.

### Enable (ENA) and Internal Slow Start

The TPS5435x has an internal digital slow start that ramps the reference voltage to its final value in 1150 switching cycles. The internal slow-start time (10% to 90%) is approximated by the following expression:

$$T_{SS\_INTERNAL}^{(ms)} = \frac{1.15k}{f_s \text{ (kHz)} \times n}$$

Use n in Table 2.

(3)

**Table 2. Slow-Start Characteristics**

DEVICE	n
TPS54352	1.485
TPS54353	1.2
TPS54354	1
TPS54355	1.084
TPS54356	0.818
TPS54357	0.900

Once the TPS5435x device is in normal regulation, the ENA pin is high. If ENA is pulled below the stop threshold of 0.5 V, switching stops and the internal slow start resets. If an application requires the TPS5435x to be disabled, use open-drain or open-collector output logic to interface to ENA (see [Figure 2](#)). ENA has an internal pullup current source. Do not use external pullup resistors.

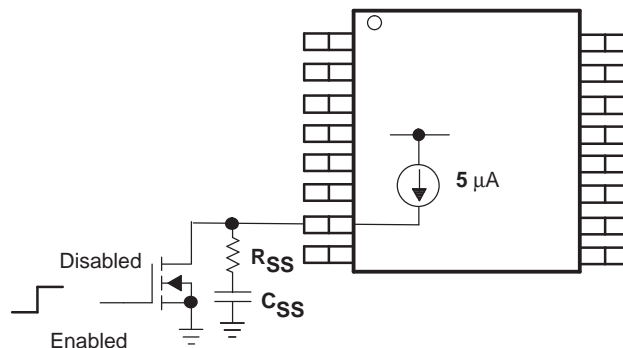

**Figure 2. Interfacing to the ENA Pin**



## Extending Slow-Start Time

In applications that use large values of output capacitance, there may be a need to extend the slow-start time to prevent the startup current from tripping the current limit. The current-limit circuit is designed to disable the high-side MOSFET and reset the internal voltage reference for a short amount of time when the high-side MOSFET current exceeds the current-limit threshold. If the output capacitance and load current cause the startup current to exceed the current-limit threshold, the power-supply output will not reach the desired output voltage. To extend the slow-start time and to reduce the startup current, an external resistor and capacitor can be added to the ENA pin. The slow-start capacitance is calculated using the following equation:

$$C_{SS} (\mu\text{F}) = 5.55 \times 10^{-3} \times n \times T_{SS} (\text{ms})$$

Use n in Table 2.

(4)

The  $R_{SS}$  resistor must be 2 k $\Omega$  and the slow-start capacitor must be less than 0.47  $\mu\text{F}$ .

## Switching Frequency (RT)

The TPS5435x has an internal oscillator that operates at twice the PWM switching frequency. The internal oscillator frequency is controlled by the RT pin. Grounding RT sets the PWM switching frequency to a default frequency of 250 kHz. Floating RT sets the PWM switching frequency to 500 kHz.

Connecting a resistor from RT to AGND sets the frequency according to the following equation (also see [Figure 30](#)).

$$RT (\text{k}\Omega) = \frac{46000}{f_s (\text{kHz}) - 35.9}$$

(5)

RT controls the SYNC pin functions. If RT is floating or grounded, SYNC is an output. If the switching frequency has been programmed using a resistor from RT to AGND, SYNC functions as an input.

The internal voltage-ramp charging current increases linearly with the set frequency and keeps the feed-forward modulator constant ( $K_m = 8$ ), regardless of the frequency set point.

**Table 3.**

SWITCHING FREQUENCY	SYNC PIN	RT PIN
250 kHz, internally set	Generates SYNC output signal	AGND
500 kHz, internally set	Generates SYNC output signal	Float
Externally set from 250 kHz to 700 kHz	Terminate to quiet ground with 10-k $\Omega$ resistor	R = 215 k $\Omega$ to 69 k $\Omega$
Externally synchronized frequency	Synchronization signal	Set RT resistor equal to 90% to 110% of external synchronization frequency. When using a dual setup (see <a href="#">Figure 27</a> for example), if the master 35x device RT pin is left floating, use a 110-k $\Omega$ resistor to tie the slave RT pin to ground. Conversely, if the master 35x device RT pin is grounded, use a 237-k $\Omega$ resistor to tie the slave RT pin to ground.

## 180° Out-of-Phase Synchronization (SYNC)

The SYNC pin is configurable as an input or as an output, as noted in the previous section. When operating as an input, SYNC is a falling-edge-triggered signal (see [Figure 3](#), [Figure 4](#), and [Figure 19](#)). When operating as an output, the signal's falling edge is approximately 180° out of phase with the rising edge of the PH pins. Thus, two TPS5435x devices operating in a system can share an input capacitor and draw ripple current at twice the frequency of a single unit.

When operating the two TPS5435x devices 180° out of phase, the total RMS input current is reduced, thus, reducing the amount of input capacitance needed and increasing efficiency.

When synchronizing a TPS5435x to an external signal, the timing resistor on the RT pin must be set so that the oscillator is programmed to run at 90% to 110% of the synchronization frequency.

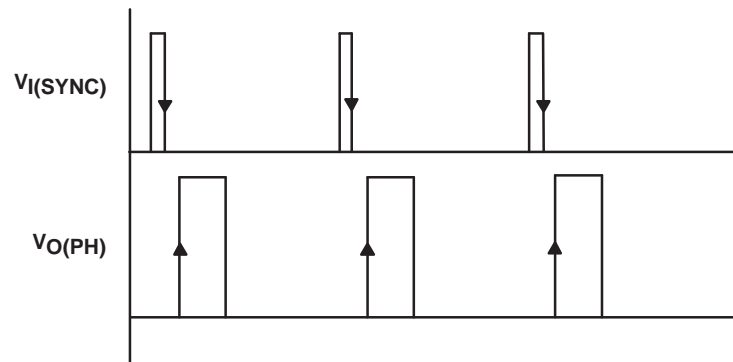

Figure 3. SYNC Input Waveform

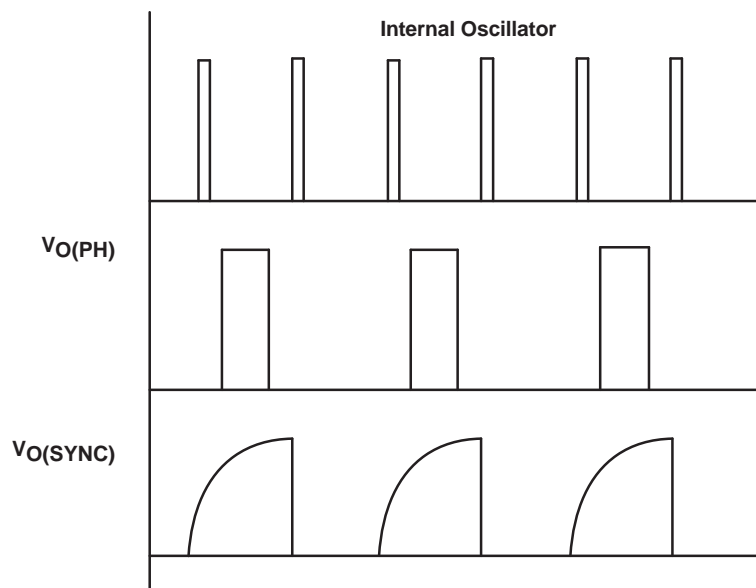

Figure 4. SYNC Output Waveform

### Power Good (PWRGD)

The VSENSE pin is compared to an internal reference signal if the VSENSE is greater than 97% and no other faults are present. The PWRGD pin presents a high impedance. A low on PWRGD indicates a fault. PWRGD has been designed to provide a weak pulldown and indicates a fault even when the device is unpowered. If the TPS5435x has power and has any fault flag set, the TPS5435x indicates the power is not good by driving the PWRGD pin low. The following events, singly or in combination, indicate power is not good:

- VSENSE pin out of bounds
- Overcurrent
- Thermal shutdown
- UVLO undervoltage
- Input voltage not present (weak pulldown)
- Slow starting
- VBIAS voltage is low.

Once the PWRGD pin presents a high impedance (i.e., power is good), a VSENSE pin out-of-bounds condition forces PWRGD low (i.e., power is bad) after a time delay. This time delay is a function of the switching frequency and is calculated using equation 6:

$$T_{\text{delay}} = \frac{1000}{f_s \text{ (kHz)}} \text{ ms} \quad (6)$$

### Bias Voltage (VBIAS)

The VBIAS regulator provides a stable supply for the internal analog circuits and the low-side gate driver. Up to 1 mA of current can be drawn for use in an external application circuit. The VBIAS pin must have a bypass capacitor value of 1  $\mu\text{F}$ . X7R- or X5R-grade dielectric ceramic capacitors are recommended because of their stable characteristics over temperature.

### Bootstrap Voltage (BOOT)

The BOOT capacitor obtains its charge cycle by cycle from the VBIAS capacitor. A capacitor from the BOOT pin to the PH pins is required for operation. The bootstrap connection for the high-side driver must have a bypass capacitor of 0.1  $\mu\text{F}$ .

### Error Amplifier

The VSENSE pin is the error amplifier inverting input. The error amplifier is a true voltage amplifier, with 1.5 mA of drive capability with a minimum of 60 dB of open-loop voltage gain and a unity-gain bandwidth of 2 MHz.

### Voltage Reference

The voltage-reference system produces a precision reference signal by scaling the output of a temperature-stable bandgap circuit. During production testing, the bandgap and scaling circuits are trimmed to produce 0.891 V at the output of the error amplifier, with the amplifier connected as a voltage follower. The trim procedure improves the regulation, since it cancels offset errors in the scaling and error-amplifier circuits.

### PWM Control and Feed Forward

Signals from the error-amplifier output, oscillator, and current-limit circuit are processed by the PWM control logic. Referring to the internal block diagram, the control logic includes the PWM comparator, PWM latch, and the adaptive dead-time control logic. During steady-state operation below the current-limit threshold, the PWM comparator output and oscillator pulse train alternately reset and set the PWM latch.

Once the PWM latch is reset, the low-side driver and integrated pulldown MOSFET remain on for a minimum duration set by the oscillator pulse width. During this period, the PWM ramp discharges rapidly to the valley voltage. When the ramp begins to charge back up, the low-side driver turns off and the high-side FET turns on. The peak PWM ramp voltage varies inversely with input voltage to maintain a constant modulator and power-stage gain of 8 V.

As the PWM ramp voltage exceeds the error-amplifier output voltage, the PWM comparator resets the latch, thus turning off the high-side FET and turning on the low-side FET. The low-side driver remains on until the next oscillator pulse discharges the PWM ramp.

During transient conditions, the error-amplifier output can be below the PWM ramp valley voltage or above the PWM peak voltage. If the error amplifier is high, the PWM latch is never reset and the high-side FET remains on until the oscillator pulse signals the control logic to turn the high-side FET off and the internal low-side FET and driver on. The device operates at its maximum duty cycle until the output voltage rises to the regulation set point, setting VSENSE to approximately the same voltage as the internal voltage reference. If the error-amplifier output is low, the PWM latch is reset continually and the high-side FET does not turn on. The internal low-side FET and low-side driver remain on until the VSENSE voltage decreases to a range that allows the PWM comparator to change states. The TPS5435x is capable of sinking current through the external low-side FET until the output voltage reaches the regulation set point.

The minimum on time is designed to be 180 ns. During the internal slow-start interval, the internal reference ramps from 0 V to 0.891 V. During the initial slow-start interval, the internal reference voltage is very small, resulting in skipped pulses because the minimum on time causes the actual output voltage to be slightly greater than the preset output voltage, until the internal reference ramps up.

## Deadtime Control

Adaptive dead-time control prevents shoot-through current from flowing in the integrated high-side MOSFET and the external low-side MOSFET during the switching transitions by actively controlling the turn-on times of the drivers. The high-side driver does not turn on until the voltage at the gate of the low-side MOSFET is below 1 V. The low-side driver does not turn on until the voltage at the gate of the high-side MOSFET is below 1 V.

## Low-Side Gate Driver (LSG)

LSG is the output of the low-side gate driver. The 100-mA MOSFET driver is capable of providing gate drive for most popular MOSFETs suitable for this application. Use the SWIFT Designer Software Tool to find the most appropriate MOSFET for the application. Connect the LSG pin directly to the gate of the low-side MOSFET. Do not use a gate resistor, as the resulting turn-on time may be too slow.

## Integrated Pulldown MOSFET

The TPS5435x has a diode-MOSFET pair from PH to PGND. The integrated MOSFET is designed for light-load continuous-conduction-mode operation when only an external Schottky diode is used. The combination of devices keeps the inductor current continuous under conditions where the load current drops below the inductor's critical current. Care should be taken in the selection of inductor in applications using only a low-side Schottky diode. Since the inductor ripple current flows through the integrated low-side MOSFET at light loads, the inductance value should be selected to limit the peak current to less than 0.3 A during the high-side FET turn-off time. The minimum value of inductance is calculated using the following equation:

$$L(H) = \frac{VO \times \left(1 - \frac{VO}{VI}\right)}{f_s \times 0.6} \quad (7)$$

## Thermal Shutdown

The device uses the thermal shutdown to turn off the MOSFET drivers and controller if the junction temperature exceeds 165°C. The device is restarted automatically when the junction temperature decreases to 7°C below the thermal shutdown trip point and starts up under control of the slow-start circuit.

## Overcurrent Protection

Overcurrent protection is implemented by sensing the drain-to-source voltage across the high-side MOSFET and compared to a voltage level that represents the overcurrent threshold limit. If the drain-to-source voltage exceeds the overcurrent threshold limit for more than 100 ns, the ENA pin is pulled low, the high-side MOSFET is disabled, and the internal digital slow-start is reset to 0 V. ENA is held low for approximately the time that is calculated by the following equation:

$$T_{\text{HICCUP}} \text{ (ms)} = \frac{2250}{f_s \text{ (kHz)}} \quad (8)$$

Once the hiccup time is complete, ENA is released and the converter initiates the internal slow start.

**TYPICAL CHARACTERISTICS**

Conditions are  $V_I = 12\text{ V}$ ,  $V_O = 3.3\text{ V}$ ,  $f_s = 500\text{ kHz}$ ,  $I_O = 3\text{ A}$ ,  $T_A = 25^\circ\text{C}$  (unless otherwise noted).

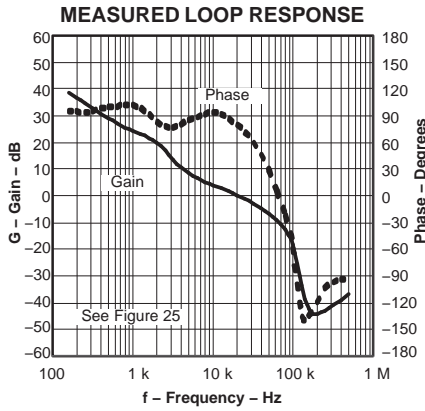

Figure 1

Figure 5.

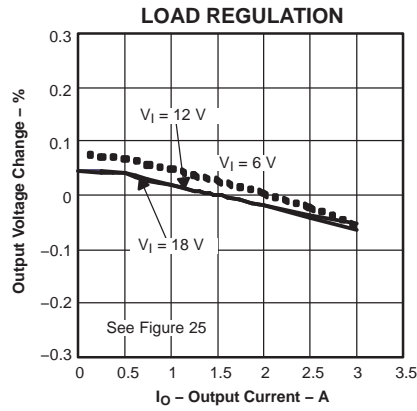

Figure 6.

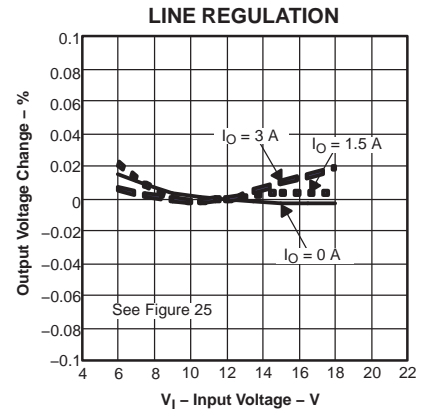

Figure 7.

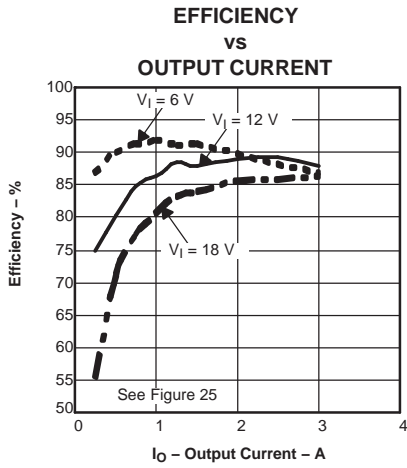

Figure 8.

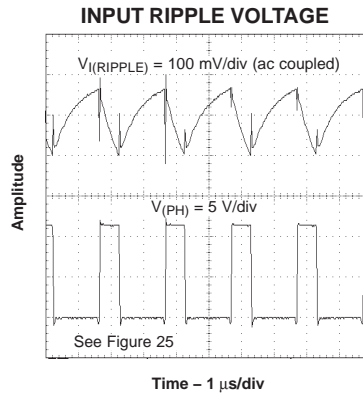

Figure 9.

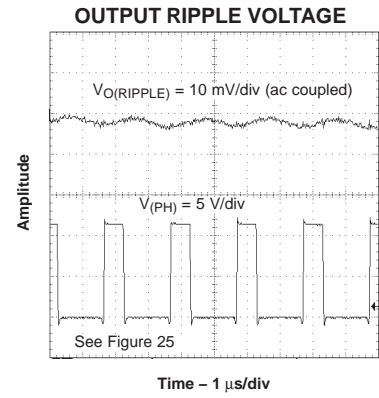

Figure 10.

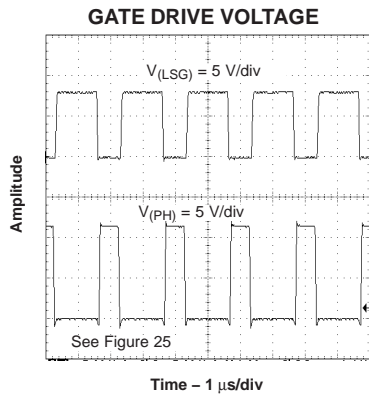

Figure 11.

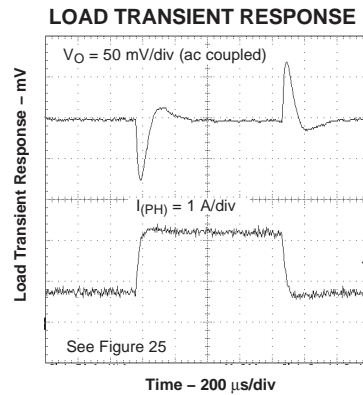

Figure 12.

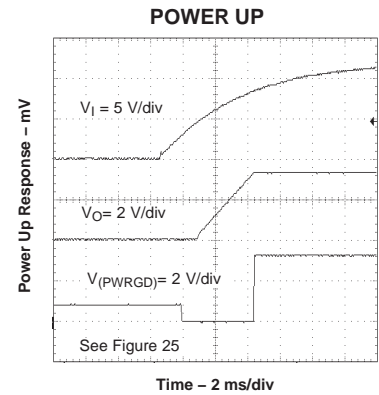

Figure 13.

**TYPICAL CHARACTERISTICS (continued)**

Conditions are  $V_I = 12\text{ V}$ ,  $V_O = 3.3\text{ V}$ ,  $f_s = 500\text{ kHz}$ ,  $I_O = 3\text{ A}$ ,  $T_A = 25^\circ\text{C}$  (unless otherwise noted).

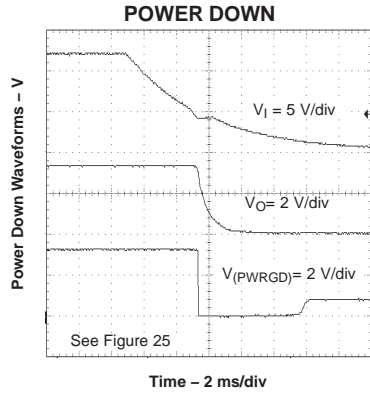

Figure 14.

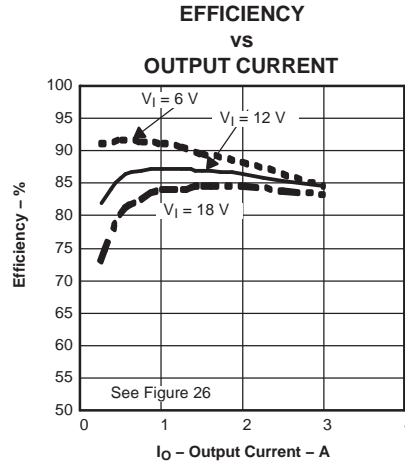

Figure 15.

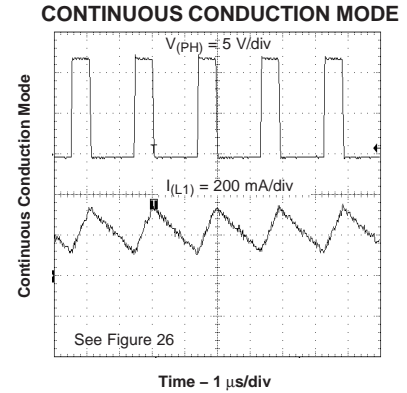

Figure 16.

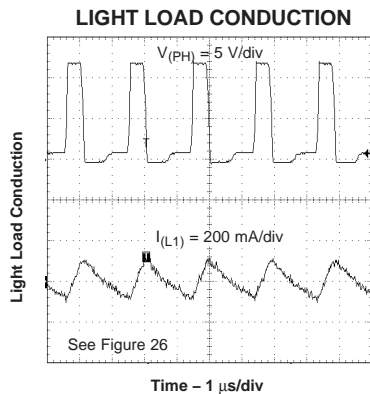

Figure 17.

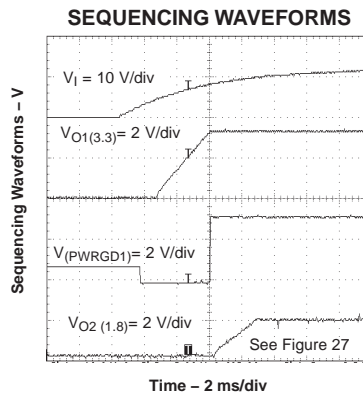

Figure 18.

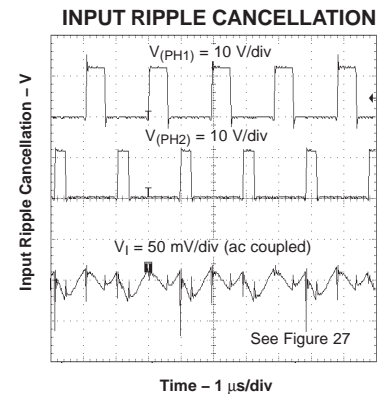

Figure 19.

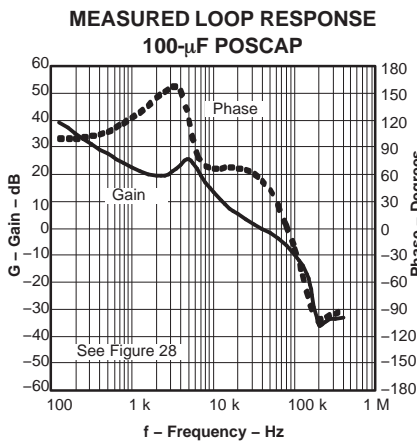

Figure 20.

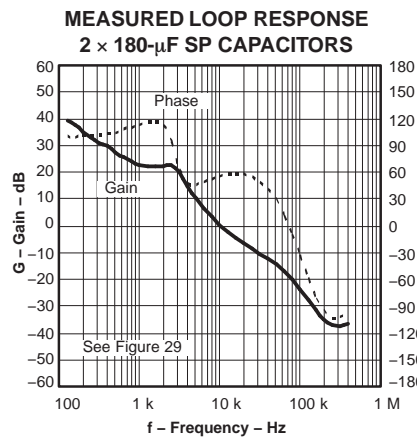

Figure 21.

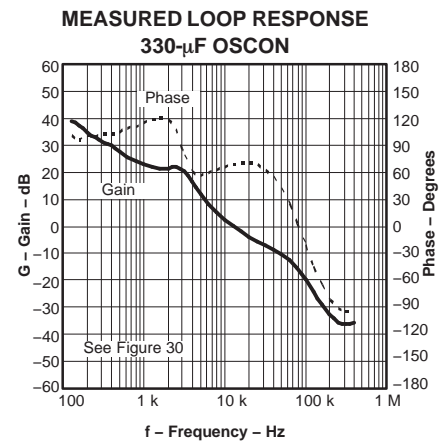
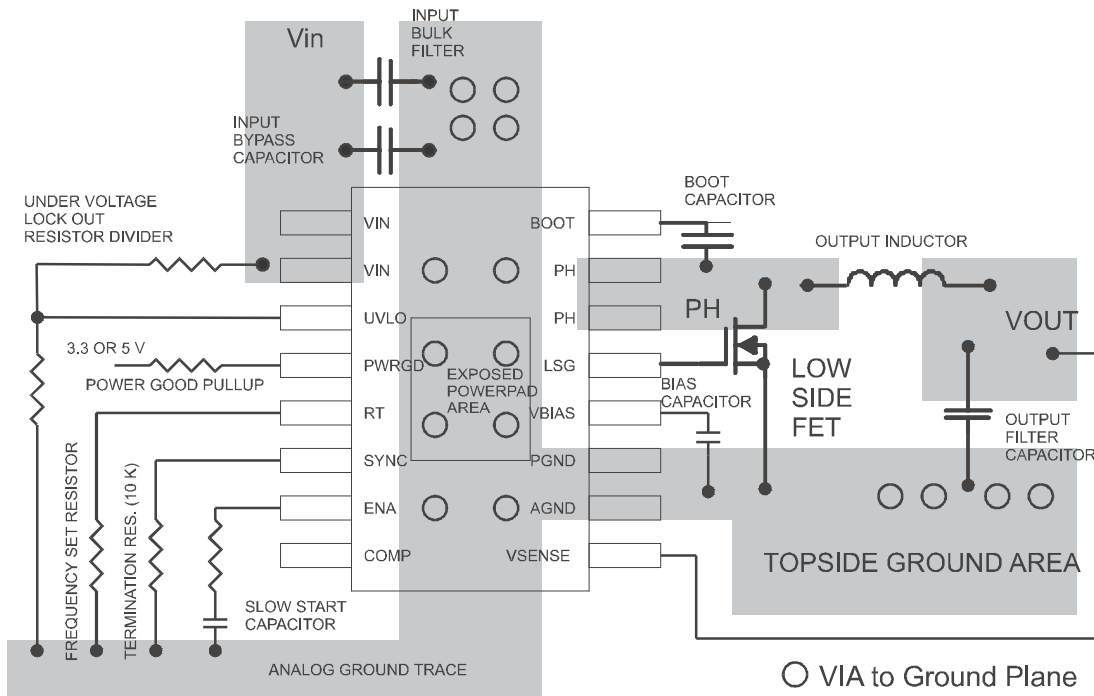

Figure 22.

## LAYOUT INFORMATION



**Figure 23. TPS5435x PCB Layout**

### PCB Layout

The VIN pins should be connected together on the printed circuit board (PCB) and bypassed with a low-ESR ceramic bypass capacitor. Care should be taken to minimize the loop area formed by the bypass capacitor connections, the VIN pins, and the TPS5435x ground pins. The minimum recommended bypass capacitance is 10- $\mu$ F ceramic with a X5R or X7R dielectric, and the optimum placement is closest to the VIN pins and the AGND and PGND pins. See [Figure 23](#) for an example of a board layout. The AGND and PGND pins should be tied to the PCB ground plane at the pins of the IC. The source of the low-side MOSFET and the anode of the Schottky diode should be connected directly to the PCB ground plane. The PH pins should be tied together and routed to the drain of the low-side MOSFET or to the cathode of the external Schottky diode. Since the PH connection is the switching node, the MOSFET (or diode) should be located very close to the PH pins, and the area of the PCB conductor minimized to prevent excessive capacitive coupling. The recommended conductor width from pins 14 and 15 is 0.050 in to 0.075 in of 1-oz copper. The length of the copper land pattern should be no more than 0.2 in.

For operation at full-rated load, the analog ground plane must provide adequate heat dissipating area. A 3-in  $\times$  3-in plane of copper is recommended, though not mandatory, dependent on ambient temperature and airflow. Most applications have larger areas of internal ground plane available, and the PowerPAD package should be connected to the largest area available. Additional areas on the bottom or top layers also help dissipate heat, and any area available should be used when 3 A or greater operation is desired. Connection from the exposed area of the PowerPAD package to the analog ground-plane layer should be made using 0.013-in diameter vias to avoid solder wicking through the vias. Four vias should be in the PowerPAD area, with four additional vias outside the pad area and underneath the package. Additional vias beyond those recommended to enhance thermal performance should be included in areas not under the device package.

**LAYOUT INFORMATION (continued)**

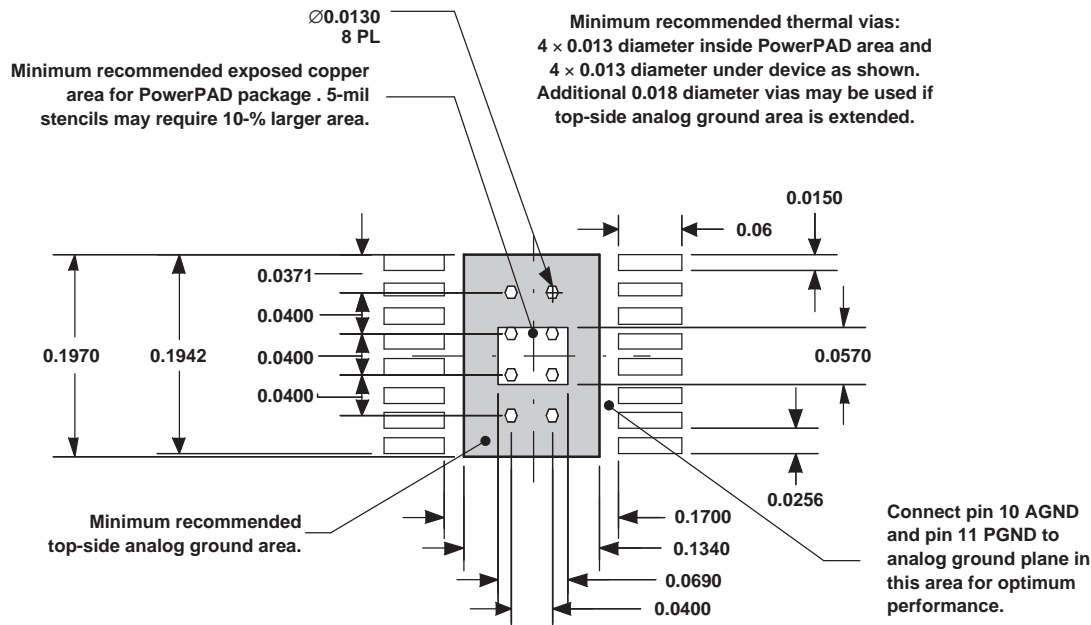

**Figure 24. Thermal Considerations for PowerPAD™ Layout**





## Input Capacitors

The TPS54356 requires an input decoupling capacitor and, depending on the application, a bulk input capacitor. The minimum value for the decoupling capacitor, C<sub>9</sub>, is 10 μF. A high-quality ceramic type X5R or X7R is recommended. The voltage rating should be greater than the maximum input voltage. Additionally, some bulk capacitance may be needed, especially if the TPS54356 circuit is not located within about 2 in from the input voltage source. The value for this capacitor is not critical, but it also should be rated to handle the maximum input voltage including ripple voltage and should filter the output so that input ripple voltage is acceptable.

This input ripple voltage can be approximated by equation 10:

$$\Delta V_{IN} = \frac{I_{OUT(MAX)} \times 0.25}{C_{BULK} \times f_{sw}} + (I_{OUT(MAX)} \times ESR_{(MAX)}) \quad (10)$$

Where:

I<sub>OUT(MAX)</sub> = Maximum load current

f<sub>SW</sub> = Switching frequency

C<sub>BULK</sub> = Bulk capacitor value

and ESR<sub>MAX</sub> = Maximum series resistance of the bulk capacitor

The maximum RMS ripple current also needs to be checked. For worst-case conditions, this can be approximated by equation 11:

$$I_{CIN} = \frac{I_{OUT(MAX)}}{2} \quad (11)$$

In this case, the input ripple voltage is 140 mV and the RMS ripple current is 1.5 A. The maximum voltage across the input capacitors is V<sub>IN</sub> max plus delta V<sub>IN</sub>/2. The chosen bulk and bypass capacitors are each rated for 25 V and the combined ripple current capacity is greater than 3 A, both providing ample margin. It is very important that the maximum ratings for voltage and current are not exceeded under any circumstance.

## Output Filter Components

### Inductor Selection

To calculate the minimum value of the output inductor, use equation 12:

$$L_{(MIN)} = \frac{V_{OUT} \times (V_{IN(MAX)} - V_{OUT})}{V_{IN(MAX)} \times K_{IND} \times I_{OUT} \times f_{sw}} \quad (12)$$

K<sub>IND</sub> is a coefficient that represents the amount of inductor ripple current relative to the maximum output current. For designs using low ESR output capacitors such as ceramics, use K<sub>IND</sub> = 0.3. When using higher ESR output capacitors, K<sub>IND</sub> = 0.2 yields better results.

For this design example, use K<sub>IND</sub> = 0.1 to keep the inductor ripple current small. The minimum inductor value is calculated to be 17.96 μH. The next-highest standard value is 22 μH, which is used in this design.

For the output filter inductor, it is important that the RMS current and saturation current ratings not be exceeded. The RMS inductor current can be derived from equation 13:

$$I_{L(RMS)} = \sqrt{I_{OUT(MAX)}^2 + \frac{1}{12} \times \left( \frac{V_{OUT} \times (V_{IN(MAX)} - V_{OUT})}{V_{IN(MAX)} \times L_{OUT} \times f_{sw} \times 0.8} \right)^2} \quad (13)$$

and the peak inductor current can be determined using equation 14:

$$I_{L(PK)} = I_{OUT(MAX)} + \frac{V_{OUT} \times (V_{IN(MAX)} - V_{OUT})}{1.6 \times V_{IN(MAX)} \times L_{OUT} \times f_{sw}} \quad (14)$$

For this design, the RMS inductor current is 3.007 A and the peak inductor current is 3.15 A. The chosen inductor is a Coiltronics DR127-220 22  $\mu$ H. It has a saturation current rating of 7.57 A and a RMS current rating of 4 A, easily meeting these requirements. A lesser-rated inductor could be used if less margin is desired. In general, inductor values for use with the TPS54356 are in the range of 6.8  $\mu$ H to 47  $\mu$ H.

### Capacitor Requirements

The important design factors for the output capacitor are dc voltage rating, ripple current rating, and equivalent series resistance (ESR). The dc voltage and ripple current ratings cannot be exceeded. The ESR is important because, along with the inductor current, it determines the amount of output ripple voltage. The actual value of the output capacitor is not critical, but some practical limits do exist.

Consider the relationship between the desired closed-loop crossover frequency of the design and LC corner frequency of the output filter. In general, it is desirable to keep the closed-loop crossover frequency at less than one-fifth of the switching frequency. With high switching frequencies such as the 500-kHz frequency of this design, internal circuit limitations of the TPS54356 limit the practical maximum crossover frequency to about 70 kHz. Additionally, the capacitor type and value must be chosen to work with the internal compensation network of the TPS5435x family of dc/dc converters. To allow for adequate phase gain in the compensation network, the LC corner frequency should be approximately one decade or so below the closed-loop crossover frequency. This limits the minimum capacitor value for the output filter to:

$$C_{OUT(MIN)} = \frac{1}{L_{OUT}} \times \left( \frac{K}{2\pi f_{CO}} \right)^2 \quad (15)$$

Where K is the frequency multiplier for the spread between  $f_{LC}$  and  $f_{CO}$ . K should be between 5 and 15, typically 10, for one decade difference. For a desired crossover of 20 kHz and a 22- $\mu$ H inductor, the minimum value for the output capacitor is 288  $\mu$ F. The selected output capacitor must be rated for a voltage greater than the desired output voltage, plus one-half the ripple voltage. Any derating amount also must be included. The maximum RMS ripple current in the output capacitor is given by equation 16:

$$I_{COUT(RMS)} = \frac{1}{\sqrt{12}} \times \left[ \frac{V_{OUT} \times (V_{IN(MAX)} - V_{OUT})}{V_{IN(MAX)} \times L_{OUT} \times f_{sw}} \right] \quad (16)$$

The calculated RMS ripple current is 156 mA in the output capacitors.

### Choosing Capacitor Value

For this design example, a relatively large aluminum electrolytic capacitor is combined with a smaller-value ceramic capacitor. This combination provides a stable high-performance design at a relatively low cost. Also, by carefully choosing the capacitor values and ESRs, the design can be tailored to complement the internal compensation poles and zeros of the TPS54356.

These preconfigured poles and zeroes, internal to the TPS54356, limit the range of output filter configurations. A variety of capacitor values and types of dielectric are supported. There are a number of different ways to calculate the output filter capacitor value and ESR to work with the internal compensation network. This procedure outlines a relatively simple procedure that produces good results with an output filter consisting of a high-ESR dielectric capacitor in parallel with a low-ESR ceramic capacitor. SWIFT Designer Software is used for designs with unusually high closed-loop crossover frequencies, low value, low-ESR output capacitors such as ceramics, or if the designer is unsure about the design procedure.

The TPS54356 contains a compensation network with the following nominal characteristics:

$$f_{INT} = 1.7 \text{ kHz}$$

$$f_{Z1} = 2.5 \text{ kHz}$$

$$f_{Z2} = 4.8 \text{ kHz}$$

$$f_{P1} = 95 \text{ kHz}$$

$$f_{P2} = 125 \text{ kHz}$$

For a stable design, the closed-loop crossover frequency should be set less than one-fifth of the switching frequency, and the phase margin at crossover must be greater than 45 degrees. The general procedure outlined here produces results consistent with these requirements, without going into great detail about the theory of loop compensation.

In this case, the output filter LC corner frequency should be selected to be near the first compensation zero frequency, as described by equation 17:

$$f_{LC} = \frac{1}{2\pi \sqrt{L_{OUT} C2}} \cong f_{Z1} \quad (17)$$

Placement of the LC corner frequency at  $f_{Z1}$  is not critical; it only needs to be close. For the design example,  $f_{LC} = 2 \text{ kHz}$ .

Solving for C2 using equation 18:

$$C2 \cong \frac{1}{4\pi^2 f^2_{Z1} L_{OUT}} \quad (18)$$

The desired value for C2 is calculated as 184  $\mu\text{F}$ . A close standard value of 330  $\mu\text{F}$  is chosen, with a resulting LC corner frequency of 1.9 kHz. As shown, this value is not critical as long as it results in a corner frequency in the vicinity of  $f_{Z1}$ .

Next, when using a large ceramic capacitor in parallel with a high-ESR electrolytic capacitor, there is a pole in the output filter that should be at  $f_{Z2}$ , as shown in equation 19:

$$f_{P(ESR)} = \frac{1}{2\pi R_{(C2ESR)} C5} = f_{Z2} \quad (19)$$

Now, the actual C2 capacitor must be selected based on the ESR and the value of capacitor C5, so that the above equation is satisfied. In this example, the  $R_{(C2ESR)} C5$  product should be  $3.18 \times 10^{-5}$ . From the available capacitors, by choosing a Panasonic EEVFKOJ331XP aluminum electrolytic capacitor with a nominal ESR of 0.34  $\Omega$  yields a calculated value for C5 of 98  $\mu\text{F}$ . The closest standard value is 100  $\mu\text{F}$ . As the actual ESR of the capacitor can vary by a large amount, this value also is not critical.

The closed-loop crossover frequency should be greater than  $f_{LC}$  and less than one-fifth of the switching frequency. Also, the crossover frequency should not exceed 70 kHz, as the error amplifier may not provide the desired gain. As stated previously, closed loop-crossover frequencies between 5 and 15 times  $f_{LC}$  work well. For this design, the crossover frequency can be estimated by:

$$f_{CO} = 1.125 \times 10^{-3} \times f_{P(ESR)} \times f_{LC} \quad (20)$$

This simplified equation is valid for this design because the output filter capacitors are mixed technology. Compare this result to the actual measured loop response plot of [Figure 5](#). The measured closed-loop crossover frequency of 19.95 kHz differs from the calculated value because the actual output filter capacitor component parameters differed slightly from the specified data-sheet values.

## Capacitor ESR and Output Ripple

The amount of output ripple voltage, as specified in the initial design parameters, is determined by the maximum ESR of the output capacitor and the input ripple current. The output ripple voltage is the inductor ripple current times the ESR of the output filter, so the maximum specified ESR as listed in the capacitor data sheet is given by equation 21:

$$ESR_{(MAX)} = \left( \frac{V_{IN(MAX)} \times L_{OUT} \times f_{sw} \times 0.8}{V_{OUT} \times (V_{IN(MAX)} - V_{OUT})} \right) \times \Delta V_{p-p(MAX)} \quad (21)$$

and the maximum ESR required is 33 mΩ. In this design, the aluminum electrolytic capacitor has an ESR of 0.340 mΩ, but it is in parallel with an ultra-low ESR ceramic capacitor of 2 mΩ maximum. The measured output ripple voltage for this design is approximately 4 mV<sub>p-p</sub>, as shown in [Figure 10](#).

## Bias AND Bootstrap Capacitors

Every TPS54356 design requires a bootstrap capacitor, C3, and a bias capacitor, C4. The bootstrap capacitor must be 0.1 μF. The bootstrap capacitor is located between the PH pins and BOOT pin. The bias capacitor is connected between the VBIAS pin and AGND. The value should be 1 μF. Both capacitors should be high-quality ceramic types with X7R or X5R grade dielectric for temperature stability. They should be placed as close to the device connection pins as possible.

## Low-Side FET

The TPS54356 is designed to operate using an external low-side FET, and the LSG pin provides the gate drive output. Connect the drain to the PH pin, the source to PGND, and the gate to LSG. The TPS54356 gate drive circuitry is designed to accommodate most common n-channel FETs that are suitable for this application. The SWIFT Designer Software can be used to calculate all the design parameters for low-side FET selection. There are some simplified guidelines that can be applied that produce an acceptable solution in most designs.

The selected FET must meet the absolute maximum ratings for the application:

- Drain-source voltage (VDSS) must be higher than the maximum voltage at the PH pin, which is  $V_{INMAX} + 0.5$  V.
- Gate-source voltage (VGSS) must be greater than 8 V.
- Drain current (Id) must be greater than  $1.1 \times I_{OUTMAX}$ .
- Drain-source on resistance (RDSON) should be as small as possible; less than 30 mΩ is desirable. Lower values for RDSON result in designs with higher efficiencies. It is important to note that the low-side FET on time typically is longer than the high-side FET on time, so attention paid to low-side FET parameters can make a marked improvement in overall efficiency.
- Total gate charge (Q<sub>g</sub>) must be less than 50 nC. Again, lower Q<sub>g</sub> characteristics result in higher efficiencies.
- Additionally, check that the device chosen is capable of dissipating the power losses.

For this design, a Fairchild FDR6674A 30-V n-channel MOSFET is used as the low-side FET. This particular FET is designed specifically to be used as a low-side synchronous rectifier.

## Power Good

The TPS54356 is provided with a power-good (PWRGD) output pin. This output is an open-drain output and is intended to be pulled up to a 3.3-V or 5-V logic supply. A 10-kΩ pullup resistor works well in this application. The absolute maximum voltage is 6 V, so care must be taken not to connect this pullup resistor to VIN if the maximum input voltage exceeds 6 V.

## Snubber Circuit

R10 and C11 of the application schematic in [Figure 25](#) comprise a snubber circuit. The snubber is included to reduce overshoot and ringing on the phase node when the internal high-side FET turns on. Since the frequency and amplitude of the ringing depends to a large degree on parasitic effects, it is best to choose these component values, based on actual measurements of any design layout. See literature number SLVP100 for more detailed information on snubber design.

[Figure 26](#) shows an application where a clamp diode is used in place of the low-side FET. The TPS54352-7 incorporates an integrated pulldown FET so that the circuit remains operating in continuous mode during light load operation. A 3-A 40-V Schottky diode, such as the Motorola MBRS340T3 or equivalent, is recommended. See [Figure 15](#), [Figure 16](#), and [Figure 17](#) for efficiency data and switching waveforms for this circuit.

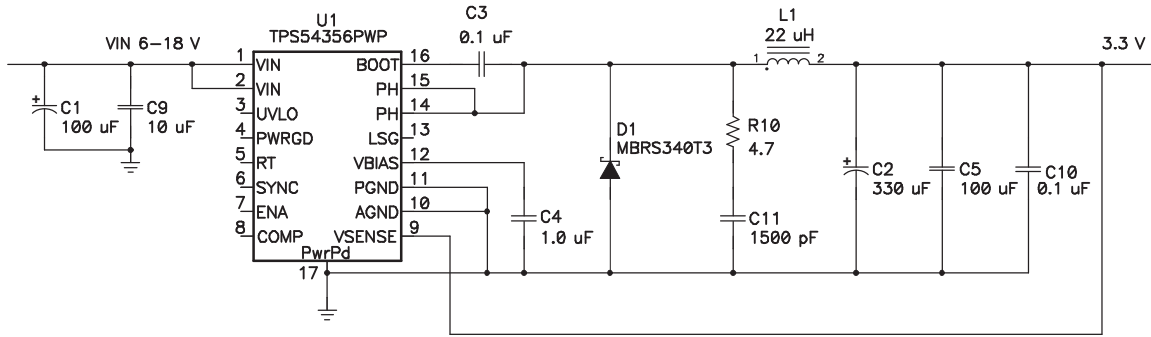

Figure 26. Power Supply With Schottky Diode

Figure 27 is an example of power-supply sequencing using a TPS54356 (U1) to generate an output of 3.3 V, and a TPS54354 (U2) to generate a 1.8-V output. These output voltages are typical I/O and core voltages for microprocessors and FPGAs. In the circuit, the 3.3-V supply is designed to power up first.

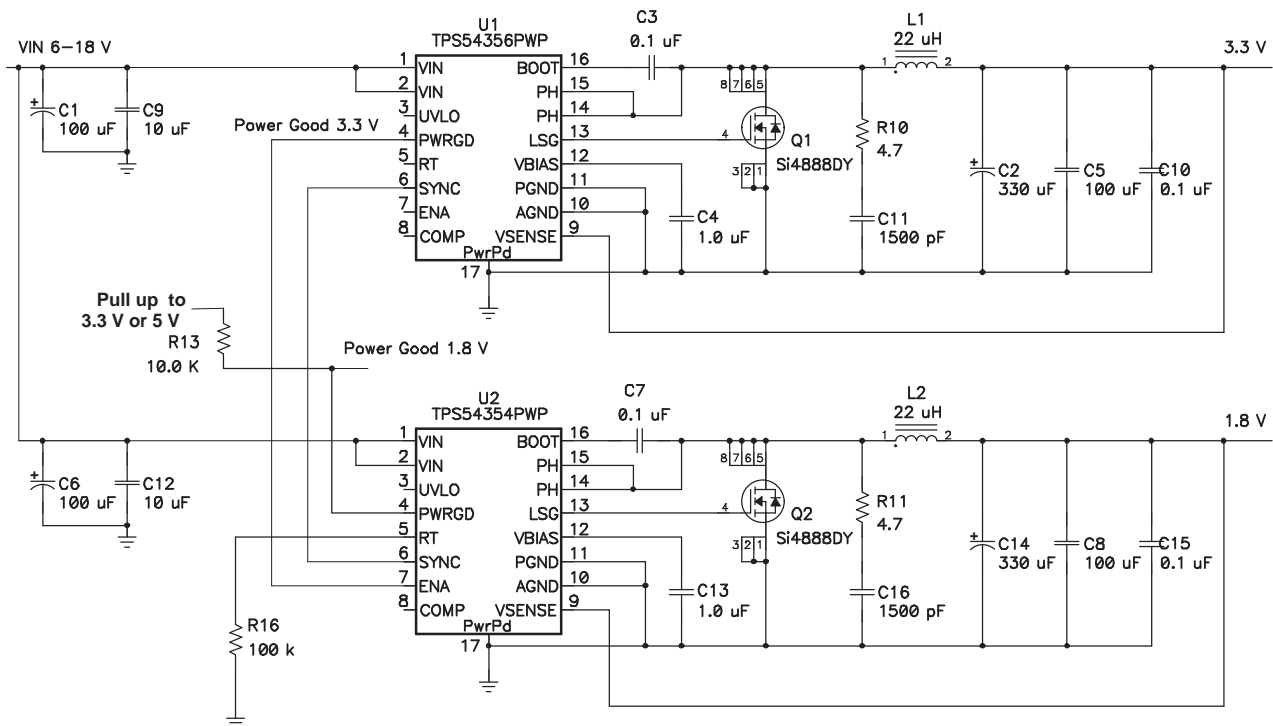

Figure 27. Power Supply With Sequencing

The PWRGD pin of U1 is tied to the ENA pin of U2 so that the 1.8-V supply starts to ramp up after the 3.3-V supply is within regulation. Figure 18 shows these start-up sequence waveforms.

Since the RT pin of U1 is floating, the SYNC pin is an output. This synchronization signal is fed the SYNC pin of U2. RT of U2 has a 110-kΩ resistor to ground, and SYNC for this device acts as an input. The 1.8-V supply operates synchronously with the 3.3-V supply, and their switching node rising edges are approximately 180 degrees out of phase, allowing for a reduction in the input voltage ripple. See Figure 19 for this waveform.

## Alternate Output Filter Designs

The previous design procedure example demonstrated a technique to design a 3.3-V power supply using both aluminum electrolytic and ceramic output filter capacitors. Other types of output filter capacitors are supported by the TPS5435x family of dc/dc converters. Figure 26, Figure 27, and Figure 28 show designs using other popular capacitor types.

In Figure 28, the TPS54356 is shown with a single 100- $\mu$ F 6-V POSCAP as the output filter capacitor. C10 is a high-frequency bypass capacitor and does not enter into the design equations. The design procedure is similar to the previous example, except in the design of the output filter. In the previous example, the output filter LC corner was set at the first zero in the compensation network, while the second compensation zero was used to counteract the output filter pole caused by the interaction of the C2 capacitor ESR with C5. In this design example, the output LC corner frequency is to be set at the second zero frequency ( $f_{z2}$ ) of the internal compensation network, approximately 5 kHz, while the first zero is used to provide phase boost prior to the LC corner frequency.

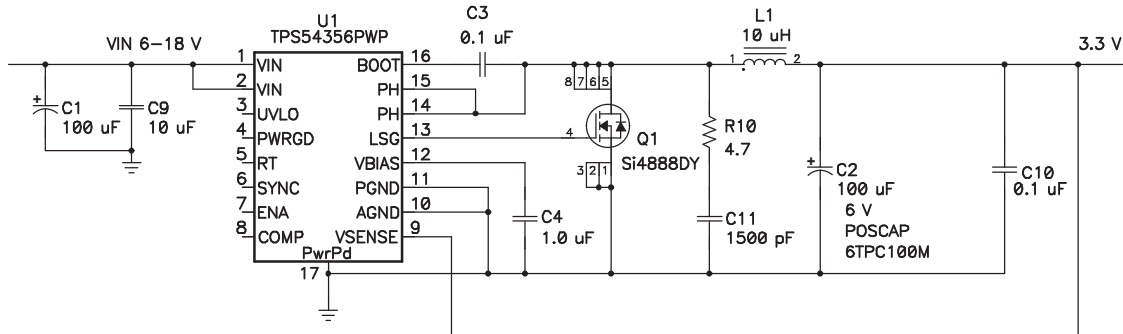

Figure 28. 3.3-V Power Supply With Sanyo POSCAP Output Filter Capacitor

### Inductor Selection

Using equation 12 and a  $K_{IND}$  0.2, the minimum inductor value required is 8.98  $\mu$ H. The closest standard value, 10  $\mu$ H, is selected. RMS and peak inductor currents are the same as calculated previously.

### Capacitor Selection

With the inductor set at 10  $\mu$ H and a desired corner frequency of 5 kHz, the output capacitor value is given by:

$$C2 = \frac{1}{4\pi^2 f_{z2}^2 L_{out}} = \frac{1}{4 \times \pi^2 \times 5000^2 \times 10^{-5}} = 101 \mu\text{F}$$

Use 100  $\mu$ F as the closest standard value.

Calculating the RMS ripple current in the output capacitor using equation 16 yields 156 mA. The POSCAP 6TPC100M capacitor selected is rated for 1700 mA. See the closed-loop response curve for this design in Figure 20.

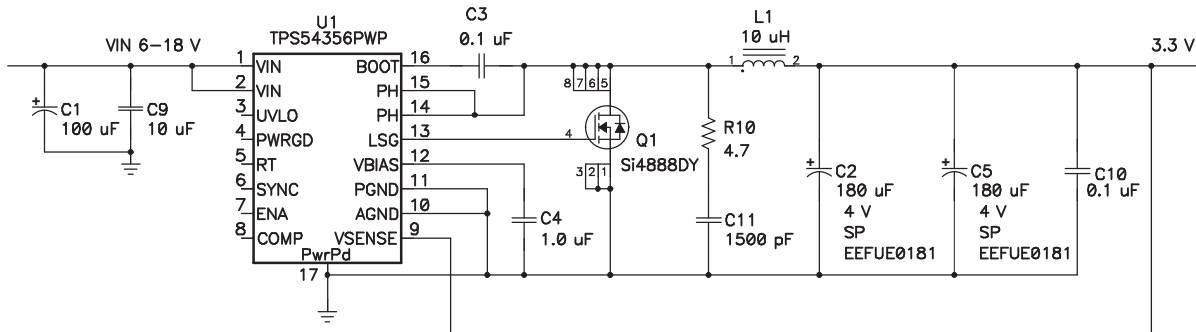

Figure 29. 3.3-V Power Supply With Panasonic SP Output Filter Capacitors

In [Figure 29](#), the TPS54356 is shown with two 180-mF 4-V special polymer dielectric output filter capacitors (C2 and C5). C10 is a high-frequency bypass capacitor and does not enter into the design equations. In the previous example, the output LC corner frequency is to be set at the second zero frequency  $f_{z2}$  of the internal compensation network, approximately 5 kHz, while the first zero is used to provide phase boost prior to the LC corner frequency. The special polymer electrolytic capacitors used in this design require that the closed-loop crossover frequency be lowered due to the significantly lower ESR of this type of capacitor.

### Inductor Selection

The inductor is the same 10- $\mu$ H value as the previous example.

### Capacitor Selection

To lower the closed-loop crossover, it is necessary to reduce the LC corner frequency below 5 kHz. Using a target value of 2500 Hz, the output capacitor value is given by:

$$C2 = \frac{1}{4\pi^2 f_{z2}^2 L_{out}} = \frac{1}{4 \times \pi^2 \times 2500^2 \times 10^{-5}} = 405 \mu\text{F}$$

Use  $2 \times 180 \mu\text{F} = 360 \mu\text{F}$  as a combination of standard values that is close to 405  $\mu\text{F}$ .

The RMS ripple current in the output capacitor is the same as before. The selected capacitors are each 3.3 A. See the closed-loop response curve for this design in [Figure 21](#).

In [Figure 30](#), the TPS54356 is shown with a Sanyo OSCON output filter capacitor (C2). C10 is a high-frequency bypass capacitor and does not enter into the design equations. This design is identical to the previous example, except that a single OSCON capacitor of 330  $\mu\text{F}$  is used for the calculated value of 405  $\mu\text{F}$ . Compare the closed-loop response for this design in [Figure 22](#) to the closed-loop response in [Figure 21](#). Note that there is only a slight difference in the response and the general similarity in both the gain and phase plots. This is the expected result for these two similar output filters.

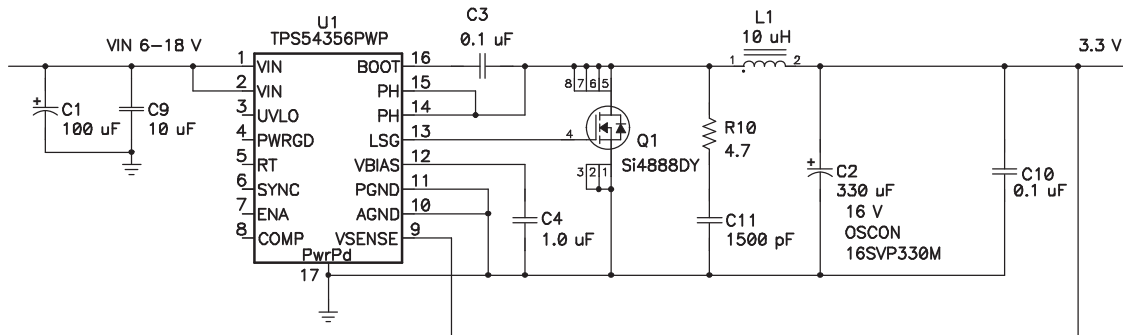

**Figure 30. 3.3-V Power Supply With Sanyo OSCON Output Filter Capacitor**

Many other additional output filter designs are possible. Use the SWIFT Designer Software to generate other designs or follow the general design procedures illustrated in this application section.



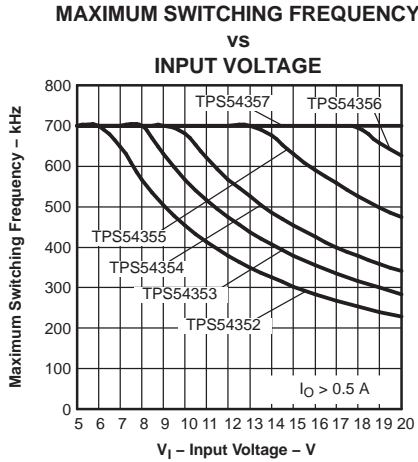

Figure 31.

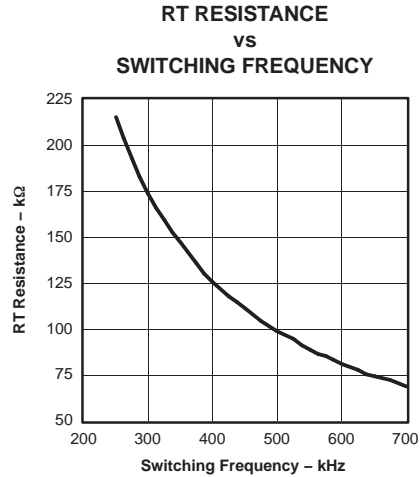

Figure 32.

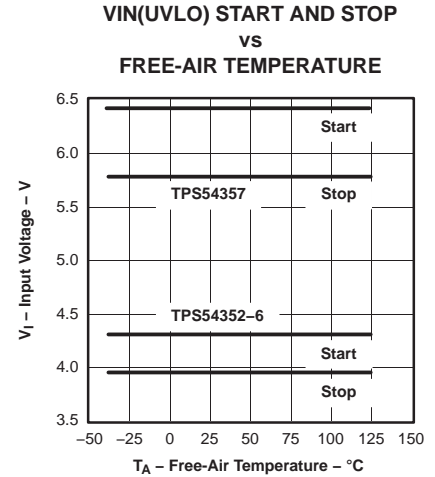

Figure 33.

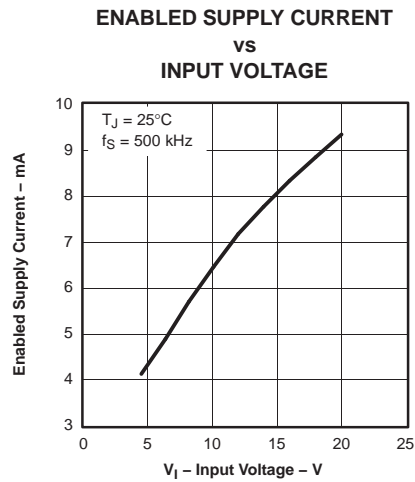

Figure 34.

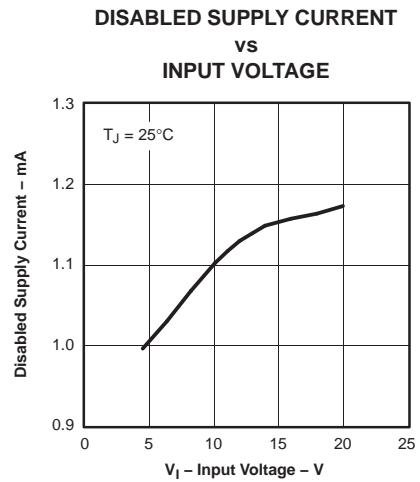

Figure 35.

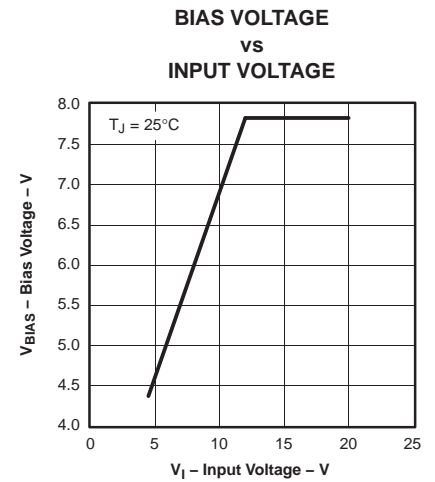

Figure 36.

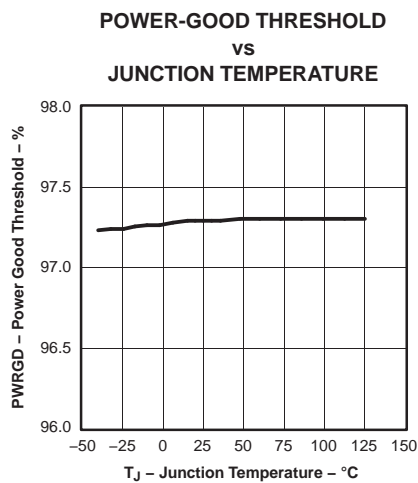

Figure 37.

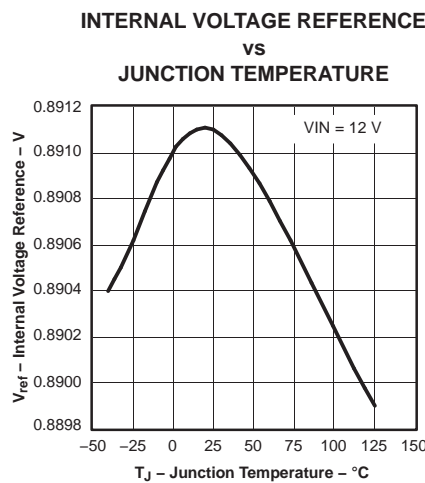

Figure 38.

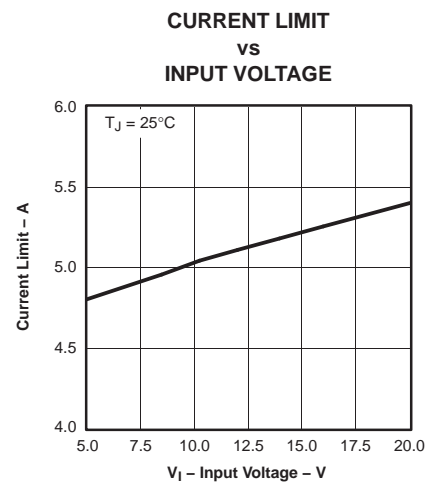

Figure 39.

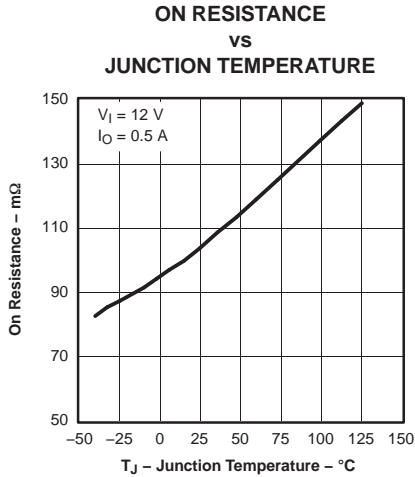

Figure 40.

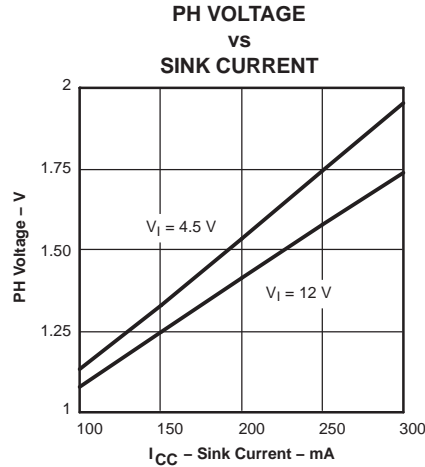

Figure 41.

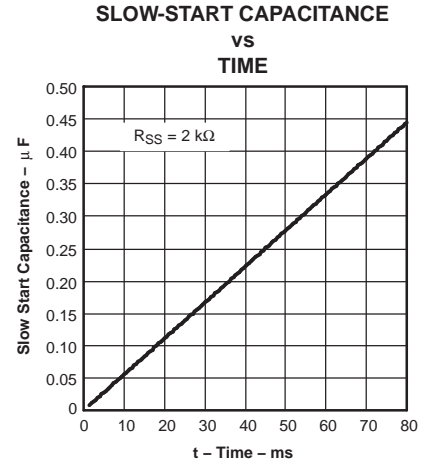

Figure 42.

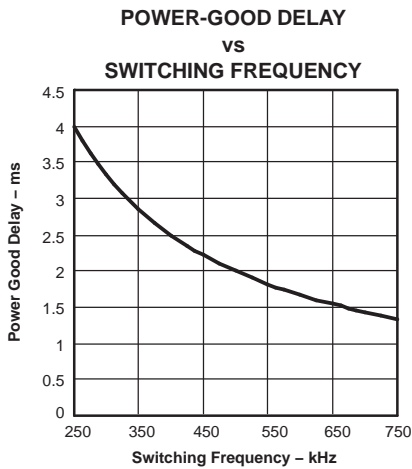

Figure 43.

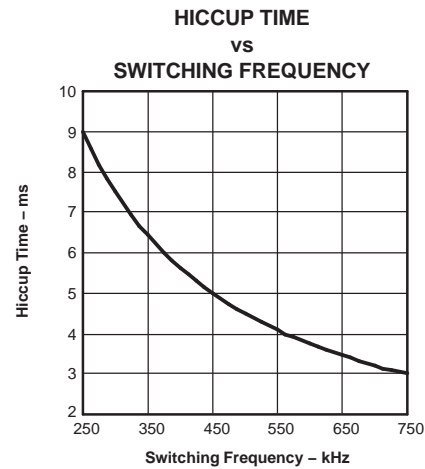

Figure 44.

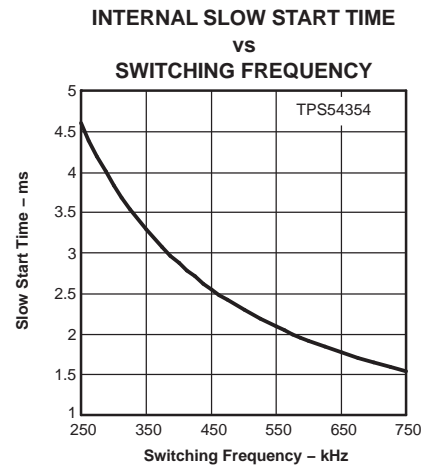

Figure 45.

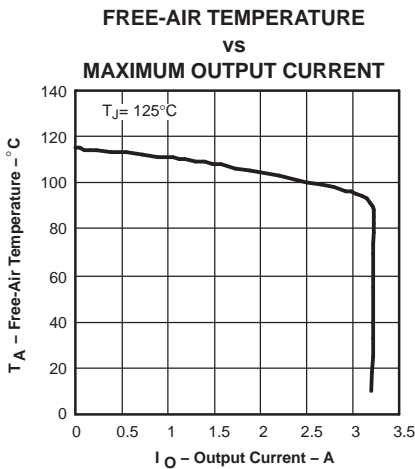

Figure 46.

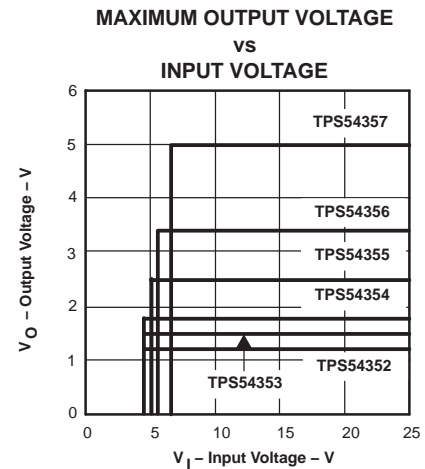

Figure 47.

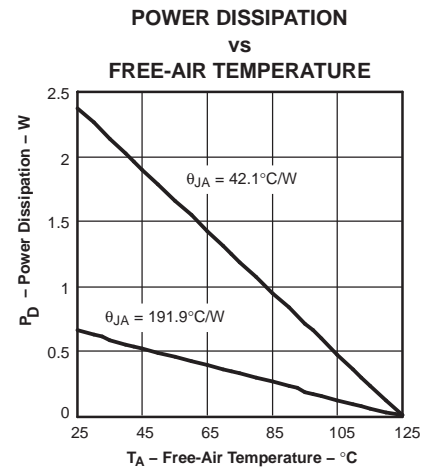
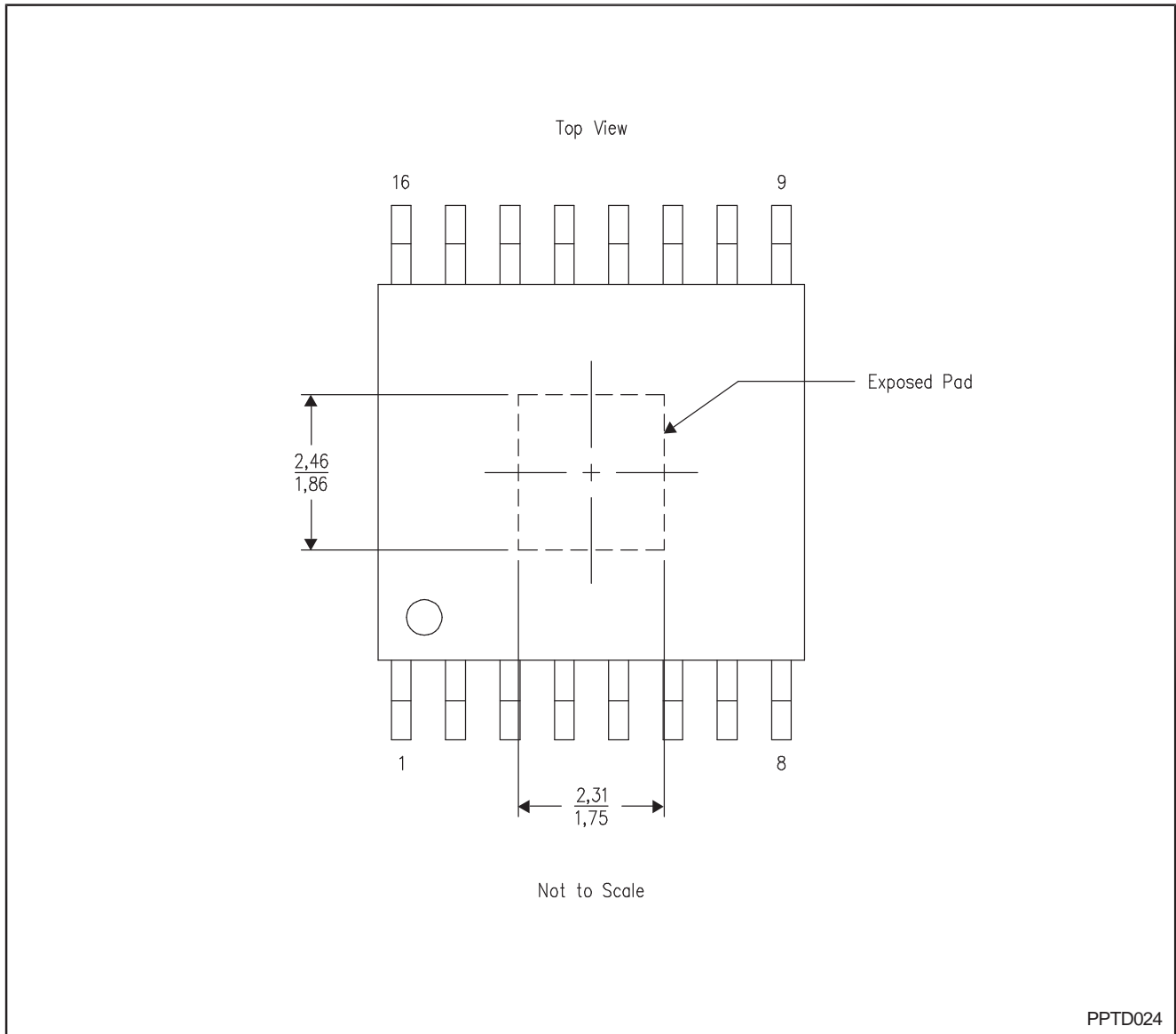

Figure 48.

**THERMAL PAD MECHANICAL DATA**

**PWP (R-PDSO-G16)**

**PowerPAD™ PLASTIC SMALL-OUTLINE**



- NOTES:
- All linear dimensions are in millimeters.
  - This drawing is subject to change without notice.
  - For additional information on the PowerPAD™ package and how to take advantage of its heat dissipating abilities, refer to Technical Brief, **PowerPAD Thermally Enhanced Package**, Texas Instruments Literature No. SLMA002 and Application Brief, **PowerPAD Made Easy**, Texas Instruments Literature No. SLMA004. Both documents are available at [www.ti.com](http://www.ti.com).

PowerPAD is a trademark of Texas Instruments

**PACKAGING INFORMATION**

Orderable Device	Status <sup>(1)</sup>	Package Type	Package Drawing	Pins	Package Qty	Eco Plan <sup>(2)</sup>	Lead/Ball Finish	MSL Peak Temp <sup>(3)</sup>
TPS54354MPWPREP	ACTIVE	HTSSOP	PWP	16	2000	Green (RoHS & no Sb/Br)	CU NIPDAU	Level-2-260C-1 YEAR
TPS54356MPWPREP	ACTIVE	HTSSOP	PWP	16	2000	Green (RoHS & no Sb/Br)	CU NIPDAU	Level-2-260C-1 YEAR
V62/07616-03XE	ACTIVE	HTSSOP	PWP	16	2000	Green (RoHS & no Sb/Br)	CU NIPDAU	Level-2-260C-1 YEAR
V62/07616-05XE	ACTIVE	HTSSOP	PWP	16	2000	Green (RoHS & no Sb/Br)	CU NIPDAU	Level-2-260C-1 YEAR

<sup>(1)</sup> The marketing status values are defined as follows:

**ACTIVE:** Product device recommended for new designs.

**LIFEBUY:** TI has announced that the device will be discontinued, and a lifetime-buy period is in effect.

**NRND:** Not recommended for new designs. Device is in production to support existing customers, but TI does not recommend using this part in a new design.

**PREVIEW:** Device has been announced but is not in production. Samples may or may not be available.

**OBSOLETE:** TI has discontinued the production of the device.

<sup>(2)</sup> Eco Plan - The planned eco-friendly classification: Pb-Free (RoHS), Pb-Free (RoHS Exempt), or Green (RoHS & no Sb/Br) - please check <http://www.ti.com/productcontent> for the latest availability information and additional product content details.

**TBD:** The Pb-Free/Green conversion plan has not been defined.

**Pb-Free (RoHS):** TI's terms "Lead-Free" or "Pb-Free" mean semiconductor products that are compatible with the current RoHS requirements for all 6 substances, including the requirement that lead not exceed 0.1% by weight in homogeneous materials. Where designed to be soldered at high temperatures, TI Pb-Free products are suitable for use in specified lead-free processes.

**Pb-Free (RoHS Exempt):** This component has a RoHS exemption for either 1) lead-based flip-chip solder bumps used between the die and package, or 2) lead-based die adhesive used between the die and leadframe. The component is otherwise considered Pb-Free (RoHS compatible) as defined above.

**Green (RoHS & no Sb/Br):** TI defines "Green" to mean Pb-Free (RoHS compatible), and free of Bromine (Br) and Antimony (Sb) based flame retardants (Br or Sb do not exceed 0.1% by weight in homogeneous material)

<sup>(3)</sup> MSL, Peak Temp. -- The Moisture Sensitivity Level rating according to the JEDEC industry standard classifications, and peak solder temperature.

**Important Information and Disclaimer:**The information provided on this page represents TI's knowledge and belief as of the date that it is provided. TI bases its knowledge and belief on information provided by third parties, and makes no representation or warranty as to the accuracy of such information. Efforts are underway to better integrate information from third parties. TI has taken and continues to take reasonable steps to provide representative and accurate information but may not have conducted destructive testing or chemical analysis on incoming materials and chemicals. TI and TI suppliers consider certain information to be proprietary, and thus CAS numbers and other limited information may not be available for release.

In no event shall TI's liability arising out of such information exceed the total purchase price of the TI part(s) at issue in this document sold by TI to Customer on an annual basis.

**OTHER QUALIFIED VERSIONS OF TPS54354-EP, TPS54356-EP :**

- Catalog: [TPS54354](#), [TPS54356](#)

NOTE: Qualified Version Definitions:

- Catalog - TI's standard catalog product

**TAPE AND REEL INFORMATION**



**QUADRANT ASSIGNMENTS FOR PIN 1 ORIENTATION IN TAPE**



\*All dimensions are nominal

Device	Package Type	Package Drawing	Pins	SPQ	Reel Diameter (mm)	Reel Width W1 (mm)	A0 (mm)	B0 (mm)	K0 (mm)	P1 (mm)	W (mm)	Pin1 Quadrant
TPS54354MPWPREP	HTSSOP	PWP	16	2000	330.0	12.4	6.67	5.4	1.6	8.0	12.0	Q1
TPS54356MPWPREP	HTSSOP	PWP	16	2000	330.0	12.4	6.67	5.4	1.6	8.0	12.0	Q1

**TAPE AND REEL BOX DIMENSIONS**



\*All dimensions are nominal

Device	Package Type	Package Drawing	Pins	SPQ	Length (mm)	Width (mm)	Height (mm)
TPS54354MPWPREP	HTSSOP	PWP	16	2000	346.0	346.0	29.0
TPS54356MPWPREP	HTSSOP	PWP	16	2000	346.0	346.0	29.0

PWP (R-PDSO-G\*\*) 20 PIN SHOWN

PowerPAD™ PLASTIC SMALL-OUTLINE PACKAGE

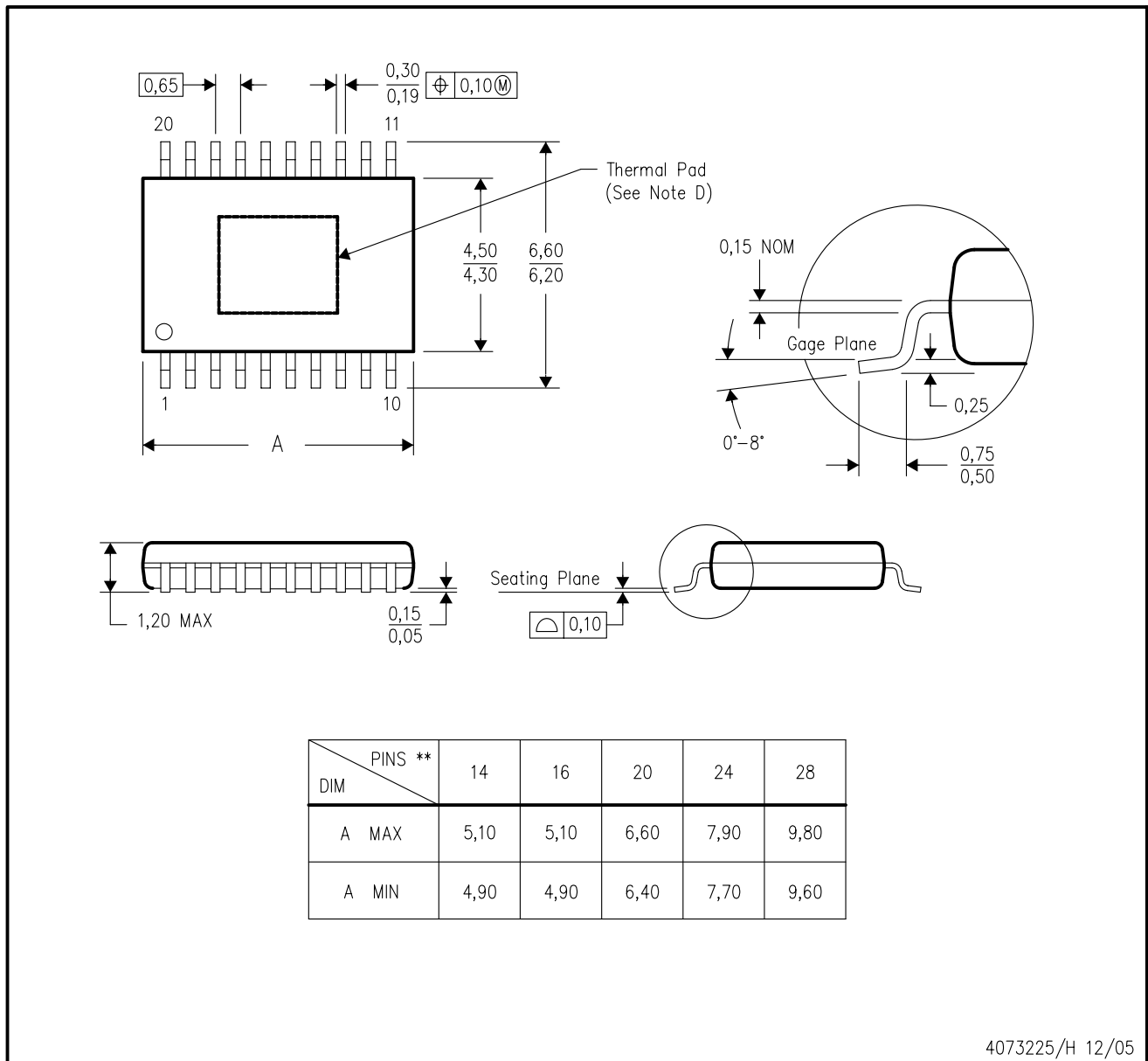

4073225/H 12/05

- NOTES:
- A. All linear dimensions are in millimeters.
  - B. This drawing is subject to change without notice.
  - C. Body dimensions do not include mold flash or protrusions. Mold flash and protrusion shall not exceed 0.15 per side.
  - D. This package is designed to be soldered to a thermal pad on the board. Refer to Technical Brief, PowerPad Thermally Enhanced Package, Texas Instruments Literature No. SLMA002 for information regarding recommended board layout. This document is available at [www.ti.com](http://www.ti.com) <<http://www.ti.com>>.
  - E. Falls within JEDEC MO-153

PowerPAD is a trademark of Texas Instruments.

THERMAL INFORMATION

This PowerPAD™ package incorporates an exposed thermal pad that is designed to be attached to a printed circuit board (PCB). The thermal pad must be soldered directly to the PCB. After soldering, the PCB can be used as a heatsink. In addition, through the use of thermal vias, the thermal pad can be attached directly to the appropriate copper plane shown in the electrical schematic for the device, or alternatively, can be attached to a special heatsink structure designed into the PCB. This design optimizes the heat transfer from the integrated circuit (IC).

For additional information on the PowerPAD package and how to take advantage of its heat dissipating abilities, refer to Technical Brief, PowerPAD Thermally Enhanced Package, Texas Instruments Literature No. SLMA002 and Application Brief, PowerPAD Made Easy, Texas Instruments Literature No. SLMA004. Both documents are available at [www.ti.com](http://www.ti.com).

The exposed thermal pad dimensions for this package are shown in the following illustration.

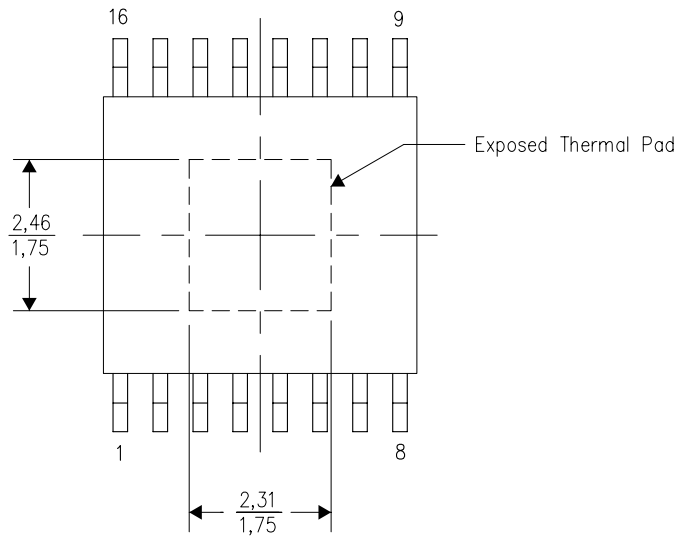

Top View

NOTE: All linear dimensions are in millimeters

Exposed Thermal Pad Dimensions



## PWP (R-PDSO-G16) PowerPAD™

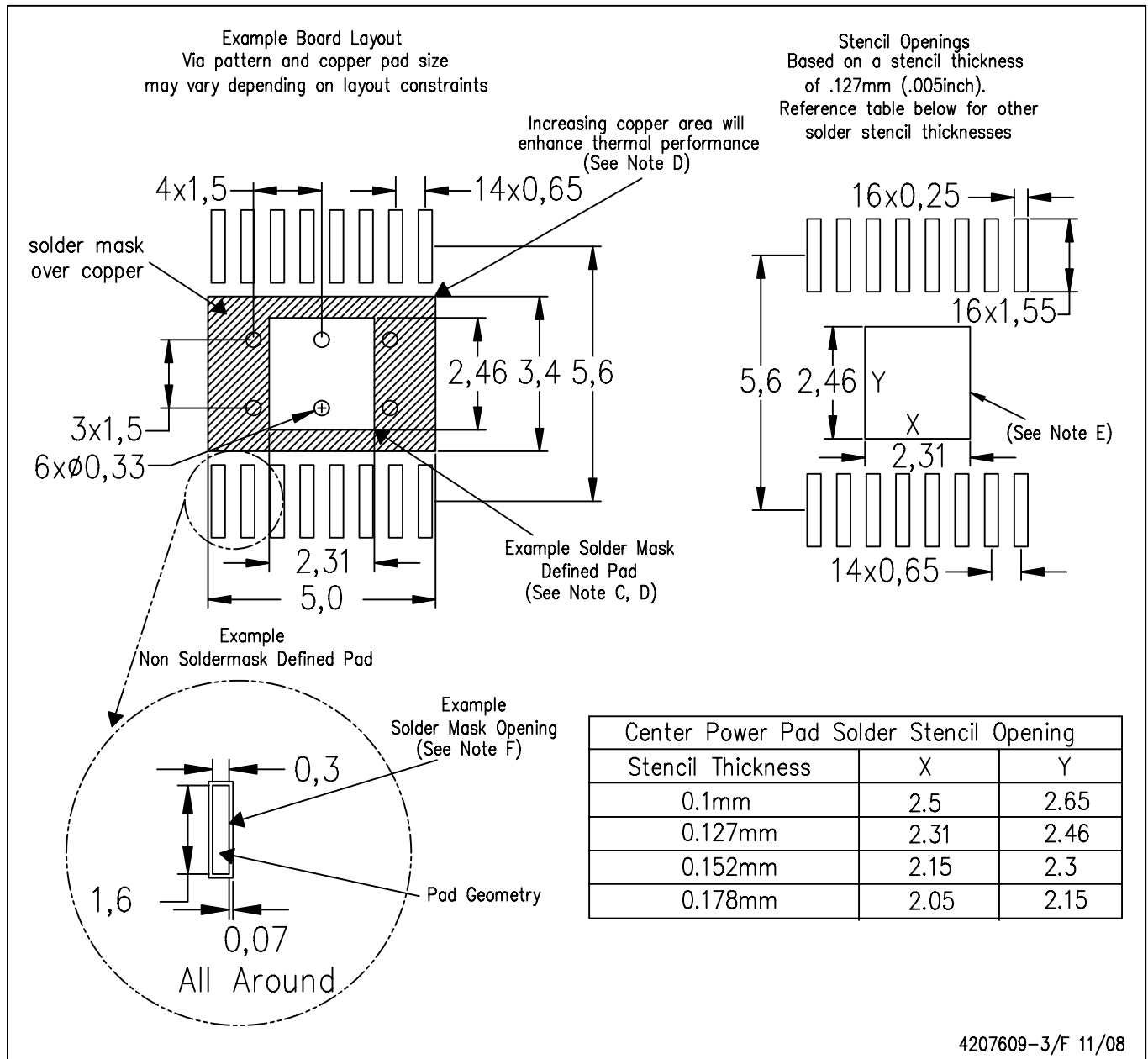

4207609-3/F 11/08

- NOTES:
- All linear dimensions are in millimeters.
  - This drawing is subject to change without notice.
  - Customers should place a note on the circuit board fabrication drawing not to alter the center solder mask defined pad.
  - This package is designed to be soldered to a thermal pad on the board. Refer to Technical Brief, PowerPad Thermally Enhanced Package, Texas Instruments Literature No. SLMA002, SLMA004, and also the Product Data Sheets for specific thermal information, via requirements, and recommended board layout. These documents are available at [www.ti.com](http://www.ti.com) <<http://www.ti.com>>. Publication IPC-7351 is recommended for alternate designs.
  - Laser cutting apertures with trapezoidal walls and also rounding corners will offer better paste release. Customers should contact their board assembly site for stencil design recommendations. Example stencil design based on a 50% volumetric metal load solder paste. Refer to IPC-7525 for other stencil recommendations.
  - Customers should contact their board fabrication site for solder mask tolerances between and around signal pads.

PowerPAD is a trademark of Texas Instruments.

## IMPORTANT NOTICE

Texas Instruments Incorporated and its subsidiaries (TI) reserve the right to make corrections, modifications, enhancements, improvements, and other changes to its products and services at any time and to discontinue any product or service without notice. Customers should obtain the latest relevant information before placing orders and should verify that such information is current and complete. All products are sold subject to TI's terms and conditions of sale supplied at the time of order acknowledgment.

TI warrants performance of its hardware products to the specifications applicable at the time of sale in accordance with TI's standard warranty. Testing and other quality control techniques are used to the extent TI deems necessary to support this warranty. Except where mandated by government requirements, testing of all parameters of each product is not necessarily performed.

TI assumes no liability for applications assistance or customer product design. Customers are responsible for their products and applications using TI components. To minimize the risks associated with customer products and applications, customers should provide adequate design and operating safeguards.

TI does not warrant or represent that any license, either express or implied, is granted under any TI patent right, copyright, mask work right, or other TI intellectual property right relating to any combination, machine, or process in which TI products or services are used. Information published by TI regarding third-party products or services does not constitute a license from TI to use such products or services or a warranty or endorsement thereof. Use of such information may require a license from a third party under the patents or other intellectual property of the third party, or a license from TI under the patents or other intellectual property of TI.

Reproduction of TI information in TI data books or data sheets is permissible only if reproduction is without alteration and is accompanied by all associated warranties, conditions, limitations, and notices. Reproduction of this information with alteration is an unfair and deceptive business practice. TI is not responsible or liable for such altered documentation. Information of third parties may be subject to additional restrictions.

Resale of TI products or services with statements different from or beyond the parameters stated by TI for that product or service voids all express and any implied warranties for the associated TI product or service and is an unfair and deceptive business practice. TI is not responsible or liable for any such statements.

TI products are not authorized for use in safety-critical applications (such as life support) where a failure of the TI product would reasonably be expected to cause severe personal injury or death, unless officers of the parties have executed an agreement specifically governing such use. Buyers represent that they have all necessary expertise in the safety and regulatory ramifications of their applications, and acknowledge and agree that they are solely responsible for all legal, regulatory and safety-related requirements concerning their products and any use of TI products in such safety-critical applications, notwithstanding any applications-related information or support that may be provided by TI. Further, Buyers must fully indemnify TI and its representatives against any damages arising out of the use of TI products in such safety-critical applications.

TI products are neither designed nor intended for use in military/aerospace applications or environments unless the TI products are specifically designated by TI as military-grade or "enhanced plastic." Only products designated by TI as military-grade meet military specifications. Buyers acknowledge and agree that any such use of TI products which TI has not designated as military-grade is solely at the Buyer's risk, and that they are solely responsible for compliance with all legal and regulatory requirements in connection with such use.

TI products are neither designed nor intended for use in automotive applications or environments unless the specific TI products are designated by TI as compliant with ISO/TS 16949 requirements. Buyers acknowledge and agree that, if they use any non-designated products in automotive applications, TI will not be responsible for any failure to meet such requirements.

Following are URLs where you can obtain information on other Texas Instruments products and application solutions:

### Products

Amplifiers	<a href="http://amplifier.ti.com">amplifier.ti.com</a>
Data Converters	<a href="http://dataconverter.ti.com">dataconverter.ti.com</a>
DSP	<a href="http://dsp.ti.com">dsp.ti.com</a>
Clocks and Timers	<a href="http://www.ti.com/clocks">www.ti.com/clocks</a>
Interface	<a href="http://interface.ti.com">interface.ti.com</a>
Logic	<a href="http://logic.ti.com">logic.ti.com</a>
Power Mgmt	<a href="http://power.ti.com">power.ti.com</a>
Microcontrollers	<a href="http://microcontroller.ti.com">microcontroller.ti.com</a>
RFID	<a href="http://www.ti-rfid.com">www.ti-rfid.com</a>
RF/IF and ZigBee® Solutions	<a href="http://www.ti.com/lprf">www.ti.com/lprf</a>

### Applications

Audio	<a href="http://www.ti.com/audio">www.ti.com/audio</a>
Automotive	<a href="http://www.ti.com/automotive">www.ti.com/automotive</a>
Broadband	<a href="http://www.ti.com/broadband">www.ti.com/broadband</a>
Digital Control	<a href="http://www.ti.com/digitalcontrol">www.ti.com/digitalcontrol</a>
Medical	<a href="http://www.ti.com/medical">www.ti.com/medical</a>
Military	<a href="http://www.ti.com/military">www.ti.com/military</a>
Optical Networking	<a href="http://www.ti.com/opticalnetwork">www.ti.com/opticalnetwork</a>
Security	<a href="http://www.ti.com/security">www.ti.com/security</a>
Telephony	<a href="http://www.ti.com/telephony">www.ti.com/telephony</a>
Video & Imaging	<a href="http://www.ti.com/video">www.ti.com/video</a>
Wireless	<a href="http://www.ti.com/wireless">www.ti.com/wireless</a>

Mailing Address: Texas Instruments, Post Office Box 655303, Dallas, Texas 75265  
Copyright © 2008, Texas Instruments Incorporated